

# CECGLB-1000IG-T.6

## 1000 Gallon Globe Trickle Tank Product Specifications

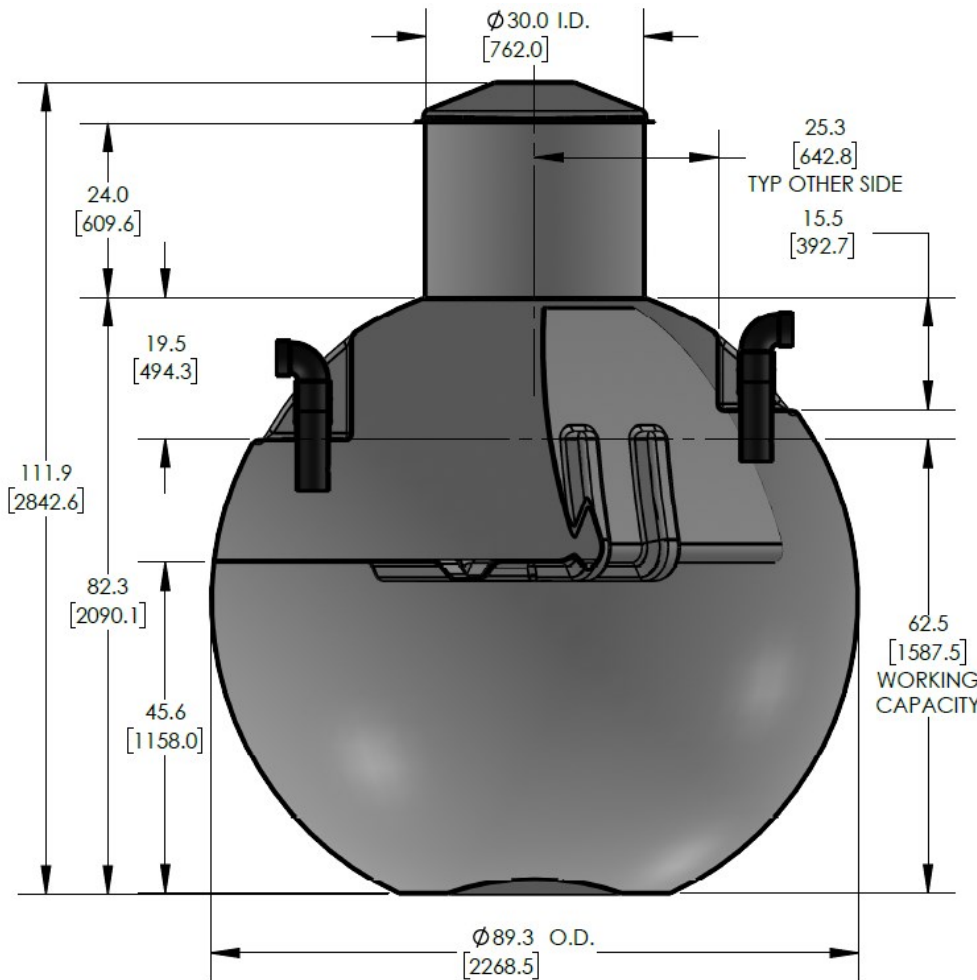

**ENGINEERED  
COMPOSITES**



### FEATURES AND BENEFITS

CSA certified design and construction

Corrosion resistant

100% neat resin construction

Virtually maintenance-free

External gelcoat for increased protection

30" wide easy-access manway

Includes 4" standard ABS inlet

Standard 10-year limited warranty

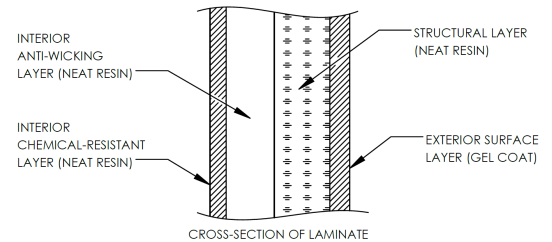

### KEY SPECIFICATIONS

Nominal volume	1,000 imp. gallons	4,546 litres
Septic volume	924 imp. gallons	4,200 litres
Effluent volume	181 imp. gallons	822 litres
Outer diameter	89.3 in	2,269 mm
Approx. weight	349 lbs	158 kg

The CECGLB-1000IG-T.6 product is a CSA-approved 1000 imp. gallon fiberglass globe trickle tank designed for burial depths up to 0.6m (2ft). The lightweight fiberglass construction provides a durable, corrosion-resistant, and high-strength structure that requires virtually zero-maintenance.

### MARKETS & APPLICATIONS



**RESIDENTIAL**



**COMMERCIAL**



**AGRICULTURAL**



**MINING**

### AVAILABLE OPTIONS

- Additional fittings & connections
- Manway extensions
- Lockable manway cover
- Hinged manway cover
- Polylok effluent filter
- Double-walled construction
- Insulated or heat-traced
- NSF potable water lining
- Full customization & engineering

[WWW.CARLSONCOMPOSITES.COM](http://WWW.CARLSONCOMPOSITES.COM)

PHONE: 1.204.233.0671

FAX: 1.204.233.6938

EMAIL: [info@carlsoncomposites.com](mailto:info@carlsoncomposites.com)