

CECGLB-750IG-H.6

750 Gallon Globe Holding Tank
Product Specifications



**ENGINEERED
COMPOSITES**

FEATURES AND BENEFITS

CSA certified design and construction

Corrosion resistant

100% neat resin construction

Virtually maintenance-free

External gelcoat for increased protection

30" wide easy-access manway

Includes 4" standard ABS inlet

Standard 10-year limited warranty

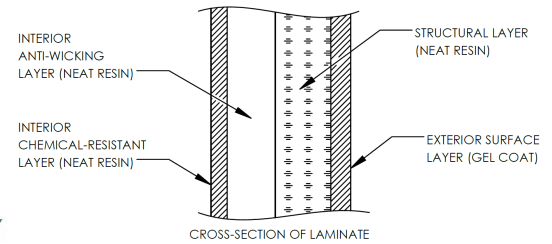
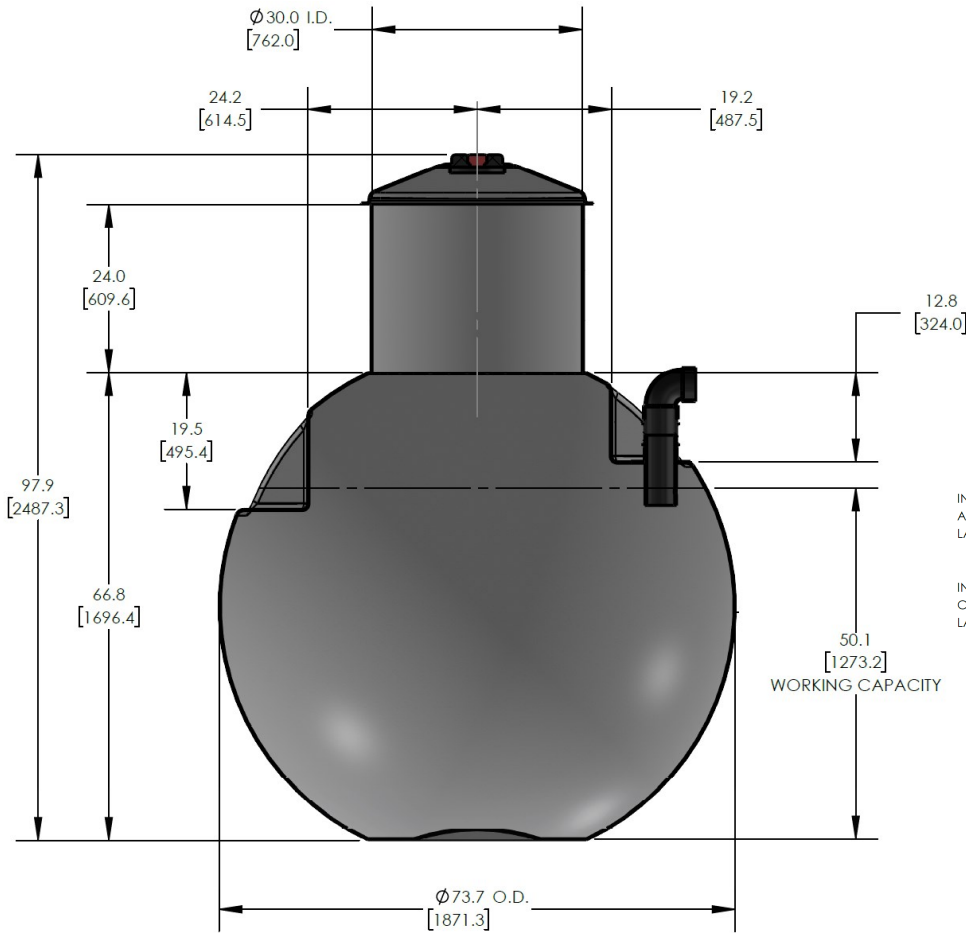

KEY SPECIFICATIONS

Nominal volume	750 imp. gallons	3,410 litres
Septic volume	604 imp. gallons	2,746 litres
Effluent volume	-	-
Outer diameter	73.7 in	1,872 mm
Approx. weight	209 lbs	95 kg

The CECGLB-750IG-H.6 product is a CSA-approved 750 imp. gallon fiberglass globe holding tank designed for burial depths up to 0.6m (2ft). The lightweight fiberglass construction provides a durable, corrosion-resistant, and high-strength structure that requires virtually zero-maintenance.

MARKETS & APPLICATIONS



RESIDENTIAL



COMMERCIAL



AGRICULTURAL



MINING

AVAILABLE OPTIONS

- Additional fittings & connections
- Manway extensions
- Lockable manway cover
- Hinged manway cover
- Polylok effluent filter
- Double-walled construction
- Insulated or heat-traced
- NSF potable water lining
- Full customization & engineering