

CECGLB-750IG-T.6

750 Gallon Globe Trickle Tank Product Specifications

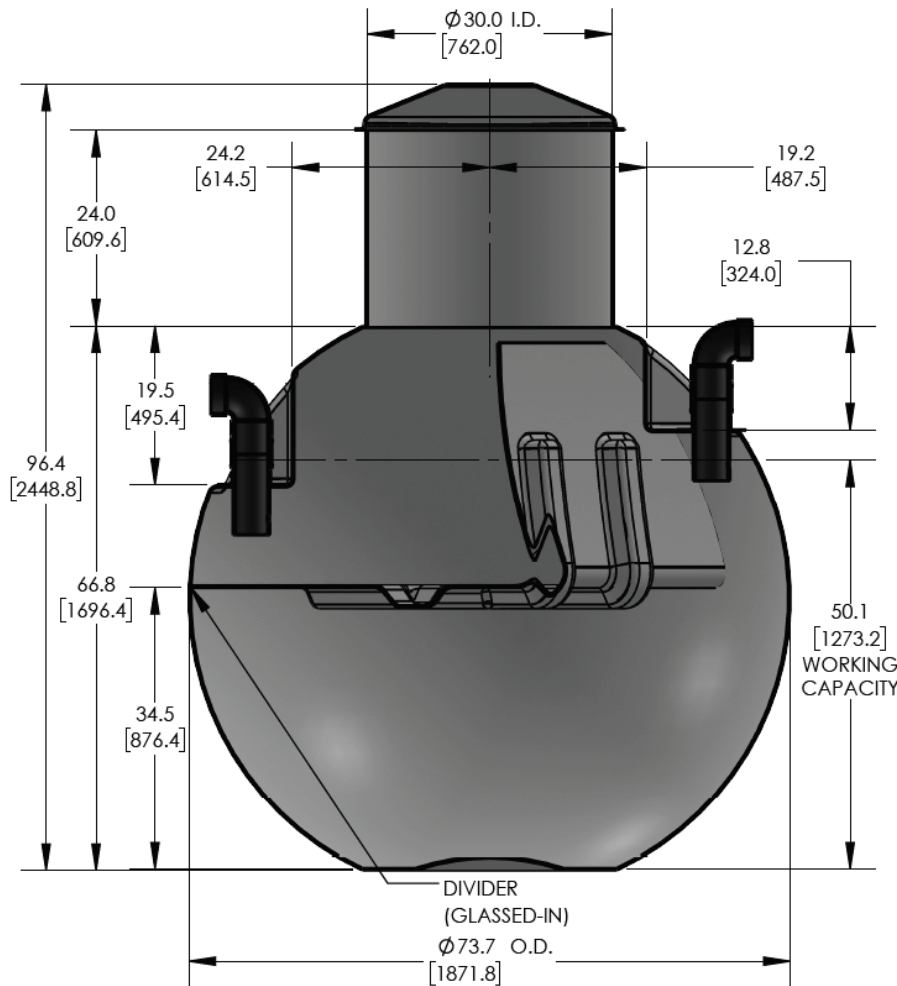

**ENGINEERED
COMPOSITES**



FEATURES AND BENEFITS

CSA certified design and construction

Corrosion resistant

100% neat resin construction

Virtually maintenance-free

External gelcoat for increased protection

30" wide easy-access manway

Includes 4" standard ABS inlet

Standard 10-year limited warranty

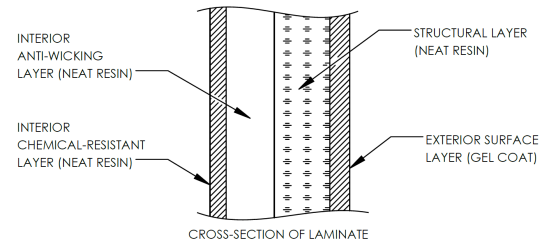

KEY SPECIFICATIONS

Nominal volume	750 imp. gallons	3,410 litres
Septic volume	488 imp. gallons	2,219 litres
Effluent volume	117 imp. gallons	532 litres
Outer diameter	73.7 in	1,872 mm
Approx. weight	257 lbs	117 kg

The CECGLB-750IG-T.6 product is a CSA-approved 750 imp. gallon fiberglass globe trickle tank designed for burial depths of up to 0.6m (2ft). The lightweight fiberglass construction provides a durable, corrosion-resistant, and high-strength structure that requires virtually zero-maintenance.

MARKETS & APPLICATIONS



RESIDENTIAL



COMMERCIAL



AGRICULTURAL



MINING

AVAILABLE OPTIONS

- Additional fittings & connections
- Manway extensions
- Lockable manway cover
- Hinged manway cover
- Polylok effluent filter
- Double-walled construction
- Insulated or heat-traced
- NSF potable water lining
- Full customization & engineering