

# CECPIL-1000IG-5H2.14

1000 Gallon Pill Style Holding Tank  
Product Specifications

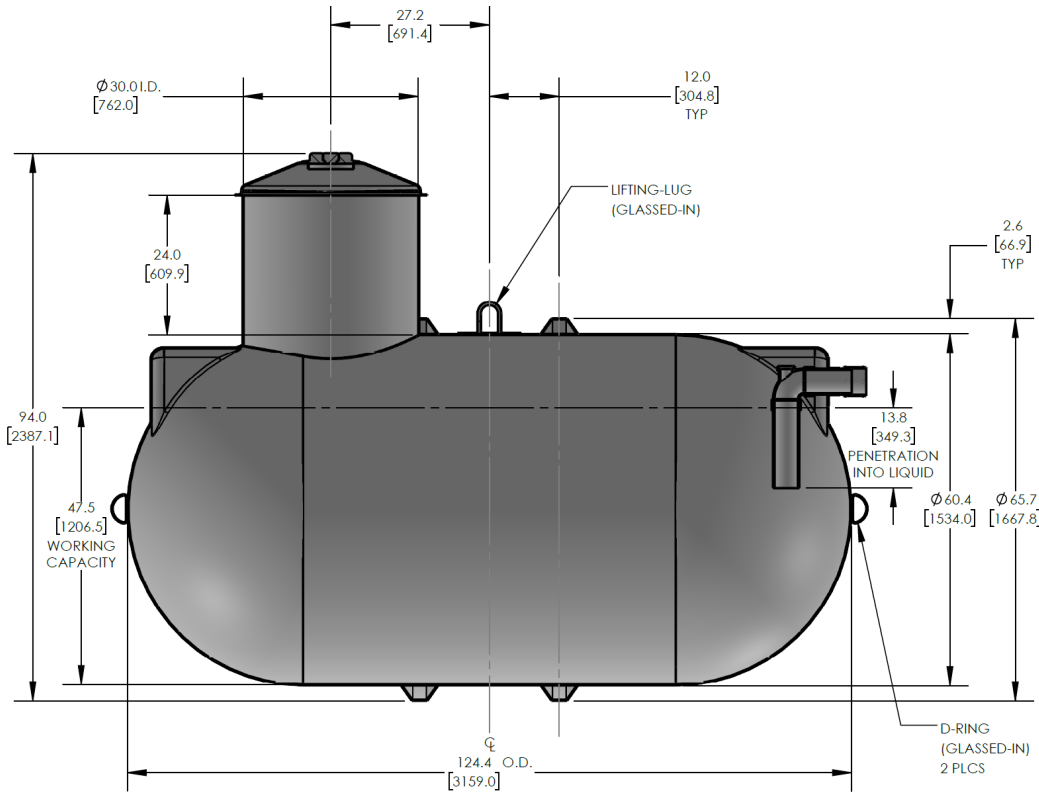

**ENGINEERED  
COMPOSITES**



## FEATURES AND BENEFITS

CSA certified design and construction

Corrosion resistant

100% neat resin construction

Virtually maintenance-free

External gelcoat for increased protection

30" wide easy-access manway

Includes 4" standard ABS inlet

Standard 10-year limited warranty

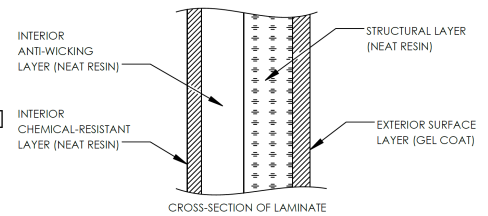

## KEY SPECIFICATIONS

Nominal volume	1,000 imp. gallons	4,546 litres
Septic volume	916 imp. gallons	4,164 litres
Effluent volume	-	-
Overall length	124.4 in	3,160 mm
Approx. weight	417 lbs	189 kg

The CECPIL-1000IG-5H2.14 product is a CSA-approved 1000 imp. gallon fiberglass pill-style holding tank designed for deep burial depths up to 2.14m (7ft). The lightweight fiberglass construction provides a durable, corrosion-resistant, and high-strength structure that requires virtually zero-maintenance.

## MARKETS & APPLICATIONS



**RESIDENTIAL**



**COMMERCIAL**



**AGRICULTURAL**



**MINING**

## AVAILABLE OPTIONS

- Additional fittings & connections
- Manway extensions
- Lockable manway cover
- Hinged manway cover
- Polylok effluent filter
- Double-walled construction
- Insulated or heat-traced
- NSF potable water lining
- Full customization & engineering

[WWW.CARLSONCOMPOSITES.COM](http://WWW.CARLSONCOMPOSITES.COM)

PHONE: 1.204.233.0671

FAX: 1.204.233.6938

EMAIL: [info@carlsoncomposites.com](mailto:info@carlsoncomposites.com)