

CECPIL-1000IG-5P.6

1000 Gallon Pill Style Pump Out Tank
Product Specifications

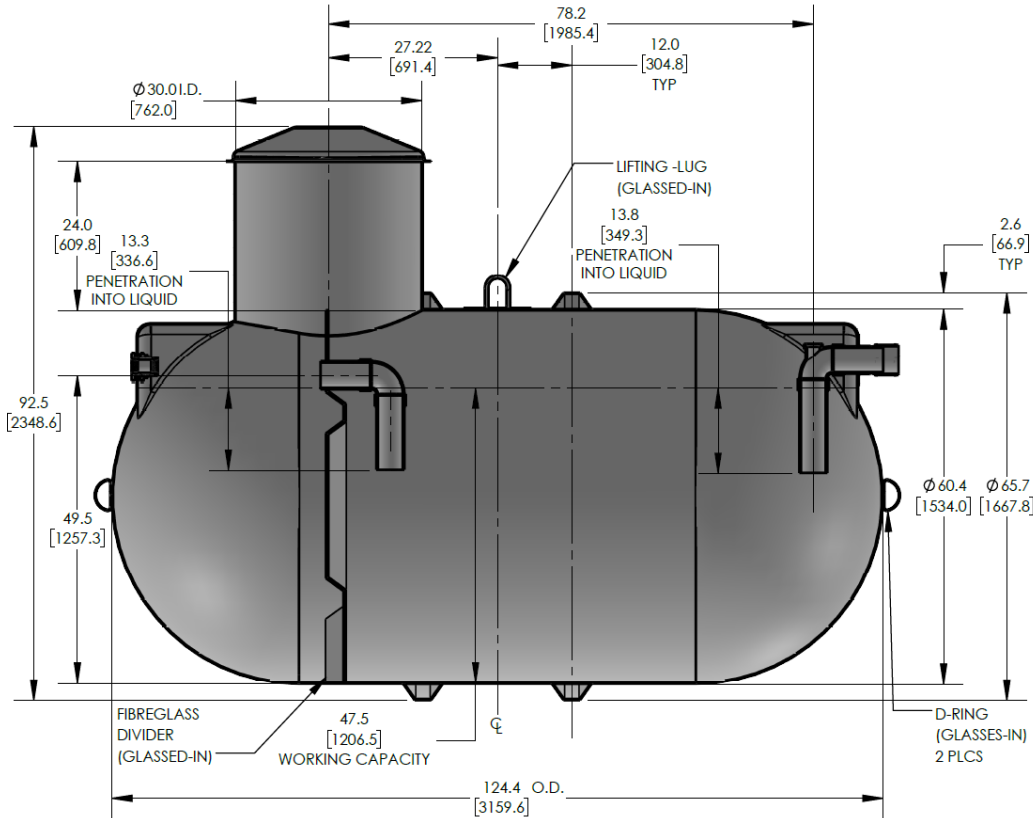

**ENGINEERED
COMPOSITES**



FEATURES AND BENEFITS

CSA certified design and construction

Corrosion resistant

100% neat resin construction

Virtually maintenance-free

External gelcoat for increased protection

30" wide easy-access manway

Includes 4" standard ABS inlet

Standard 10-year limited warranty

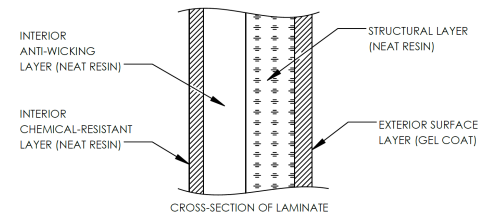

KEY SPECIFICATIONS

Nominal volume	1,000 imp. gallons	4,546 litres
Septic volume	697 imp. gallons	3,168 litres
Effluent volume	219 imp. gallons	995 litres
Overall length	124.4 in	3,160 mm
Approx. weight	390 lbs	171 kg

The CECPIL-1000IG-5P.6 product is a CSA-approved 1000 imp. gallon fiberglass pill-style pump out tank designed for shallow burial depths up to 0.6m (2ft). The lightweight fiberglass construction provides a durable, corrosion-resistant, and high-strength structure that requires virtually zero-maintenance.

MARKETS & APPLICATIONS



RESIDENTIAL



COMMERCIAL



AGRICULTURAL



MINING

AVAILABLE OPTIONS

- Additional fittings & connections
- Manway extensions
- Lockable manway cover
- Hinged manway cover
- Polylok effluent filter
- Double-walled construction
- Insulated or heat-traced
- NSF potable water lining
- Full customization & engineering