

CECPIL-1000IG-5T2.14

1000 Gallon Pill Style Trickle Tank
Product Specifications

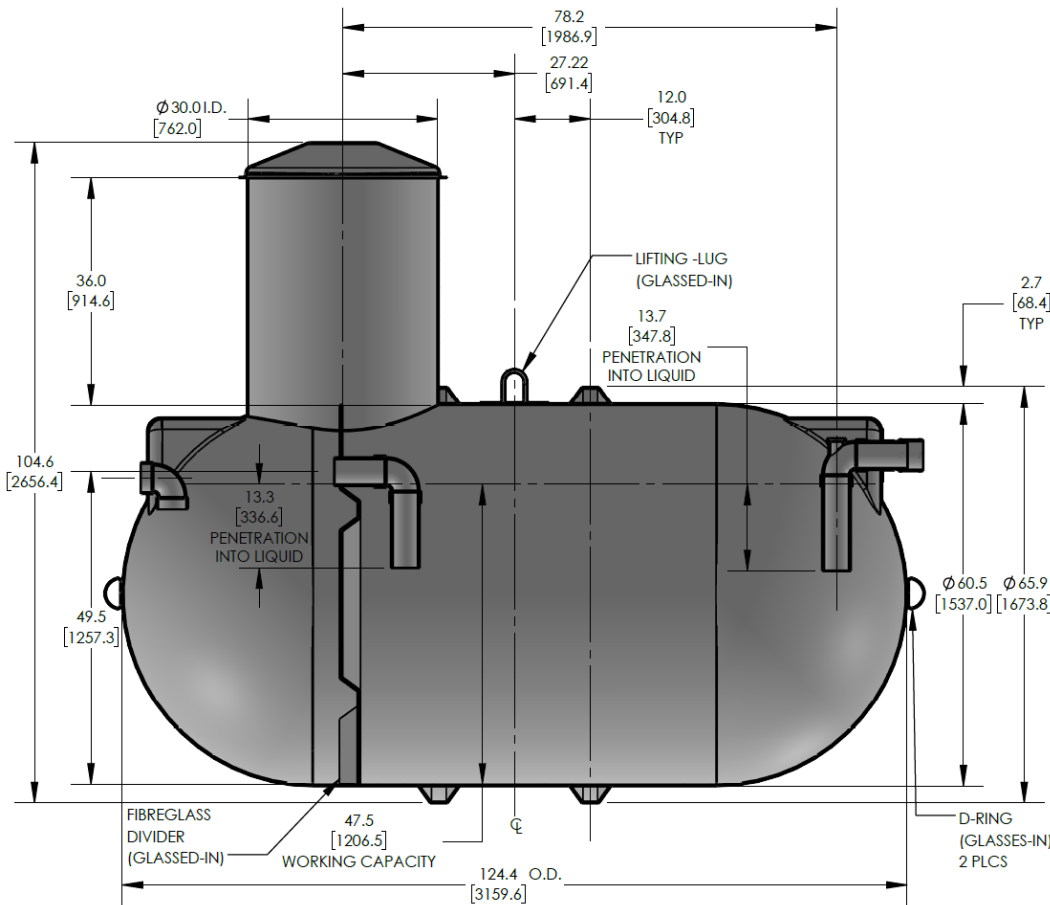

**ENGINEERED
COMPOSITES**



FEATURES AND BENEFITS

CSA certified design and construction

Corrosion resistant

100% neat resin construction

Virtually maintenance-free

External gelcoat for increased protection

30" wide easy-access manway

Includes 4" standard ABS inlet

Standard 10-year limited warranty

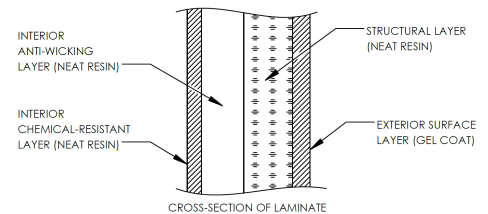

KEY SPECIFICATIONS

| | | |
|-----------------|--------------------|--------------|
| Nominal volume | 1,000 imp. gallons | 4,546 litres |
| Septic volume | 697 imp. gallons | 3,168 litres |
| Effluent volume | 219 imp. gallons | 995 litres |
| Overall length | 124.4 in | 3,160 mm |
| Approx. weight | 485 lbs | 220 kg |

The CECPIL-1000IG-5T2.14 product is a CSA-approved 1000 imp. gallon fiberglass pill-style trickle tank designed for deep burial depths up to 2.14m (7ft). The light-weight fiberglass construction provides a durable, corrosion-resistant, and high-strength structure that requires virtually zero-maintenance.

MARKETS & APPLICATIONS



RESIDENTIAL



COMMERCIAL



AGRICULTURAL



MINING

AVAILABLE OPTIONS

- Additional fittings & connections
- Manway extensions
- Lockable manway cover
- Hinged manway cover
- Polylok effluent filter
- Double-walled construction
- Insulated or heat-traced
- NSF potable water lining
- Full customization & engineering

WWW.CARLSONCOMPOSITES.COM

PHONE: 1.204.233.0671

FAX: 1.204.233.6938

EMAIL: info@carlsoncomposites.com