

CECPIL-1000IG-5W2.14

1000 Gallon Pill Style Water Tank
Product Specifications

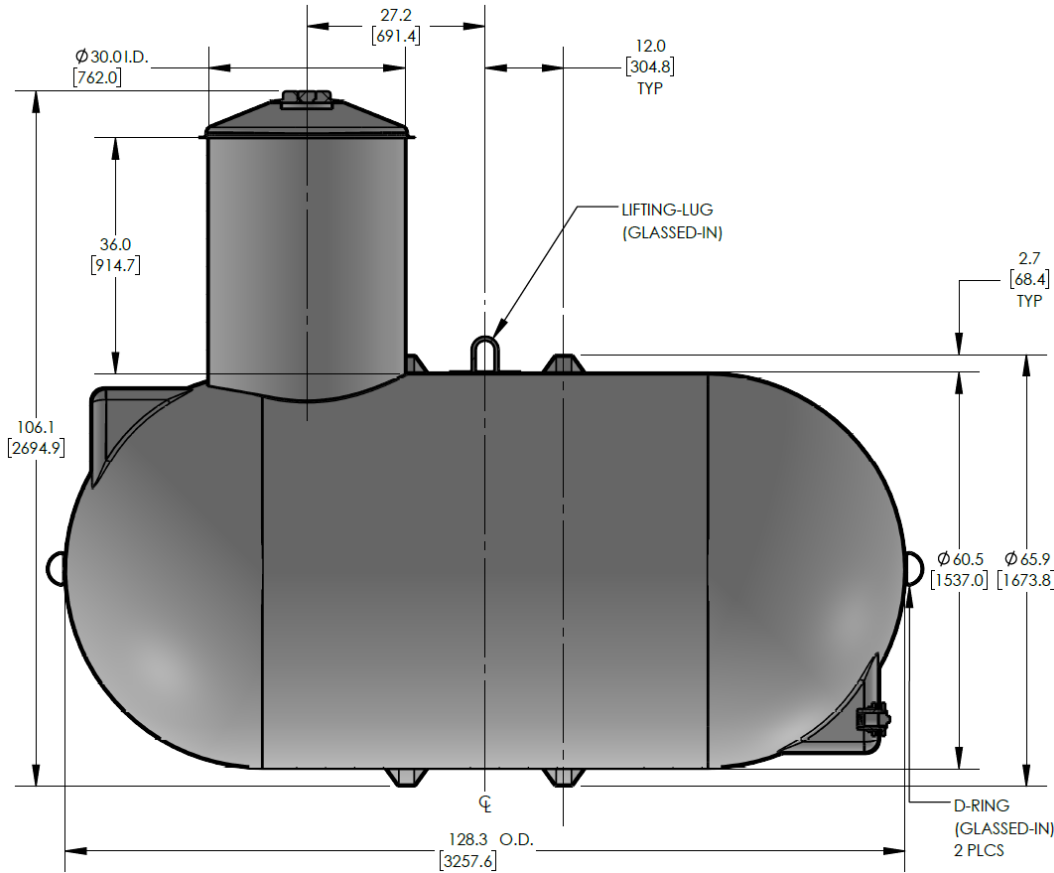

**ENGINEERED
COMPOSITES**



FEATURES AND BENEFITS

CSA certified design and construction

Corrosion resistant

100% neat resin construction

Virtually maintenance-free

External gelcoat for increased protection

30" wide easy-access manway

Includes 4" standard ABS inlet

Standard 10-year limited warranty

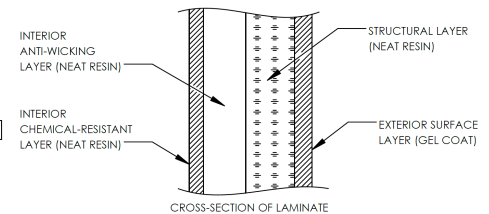

KEY SPECIFICATIONS

Nominal volume	1,000 imp. gallons	4,546 litres
Useable volume	1,107 imp. gallons	5,032 litres
Overall length	128.3 in	3,258 mm
Approx. weight	423 lbs	192 kg

The CECPIL-1000IG-5W2.14 product is a CSA-approved 1000 imp. gallon fiberglass pill-style water tank designed for burial depths up to 2.14m (7ft). The light-weight fiberglass construction provides a durable, corrosion-resistant, and high-strength structure that requires virtually zero-maintenance.

MARKETS & APPLICATIONS



RESIDENTIAL



COMMERCIAL



AGRICULTURAL



MINING

AVAILABLE OPTIONS

- Additional fittings & connections
- Manway extensions
- Lockable manway cover
- Hinged manway cover
- Polylok effluent filter
- Double-walled construction
- Insulated or heat-traced
- NSF potable water lining
- Full customization & engineering