

# CECPIL-1250IG-5P2.14

1250 Gallon Pill Style Pump Out Tank  
Product Specifications

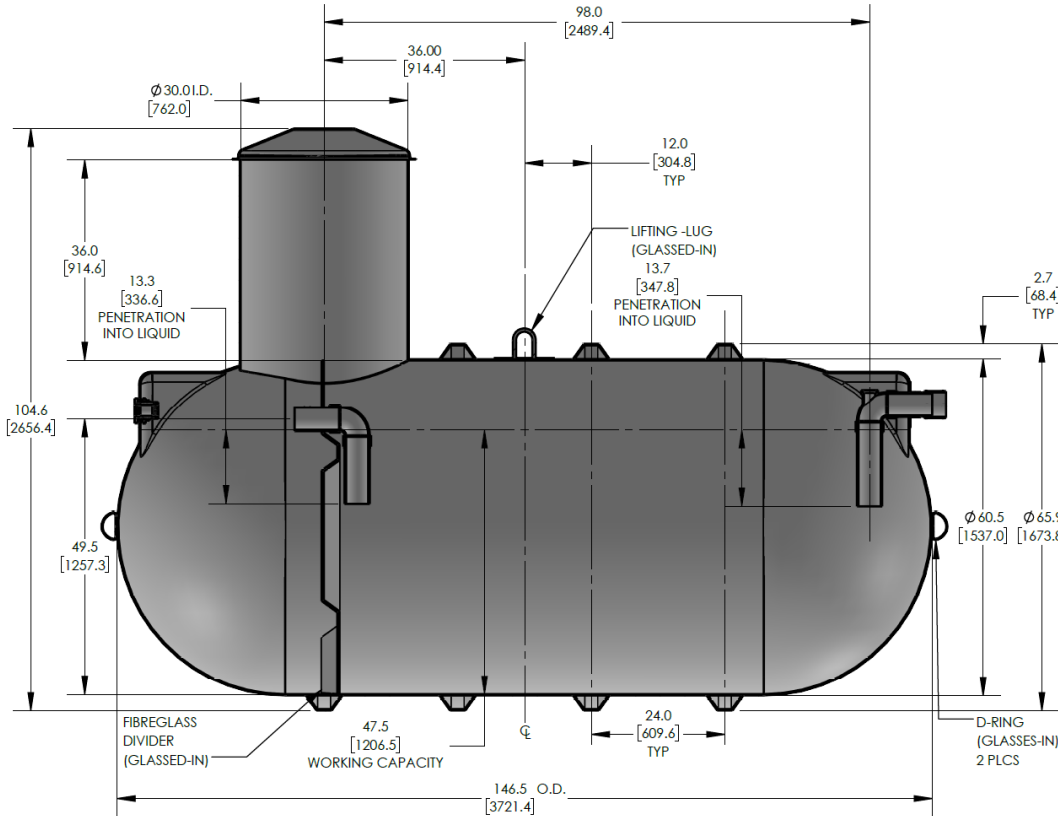

**ENGINEERED  
COMPOSITES**



## FEATURES AND BENEFITS

CSA certified design and construction

Corrosion resistant

100% neat resin construction

Virtually maintenance-free

External gelcoat for increased protection

30" wide easy-access manway

Includes 4" standard ABS inlet

Standard 10-year limited warranty

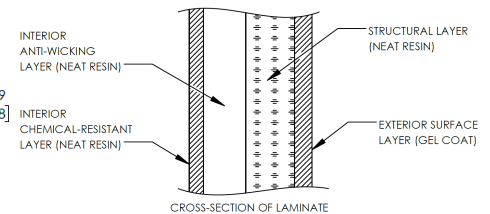

## KEY SPECIFICATIONS

Nominal volume	1,250 imp. gallons	5,682 litres
Septic volume	864 imp. gallons	3,927 litres
Effluent volume	242 imp. gallons	1,100 litres
Overall length	146.4 in	3,718 mm
Approx. weight	587 lbs	266 kg

## AVAILABLE OPTIONS

- Additional fittings & connections
- Manway extensions
- Lockable manway cover
- Hinged manway cover
- Polylok effluent filter
- Double-walled construction
- Insulated or heat-traced
- NSF potable water lining
- Full customization & engineering

The CECPIL-1250IG-5P2.14 product is a CSA-approved 1250 imp. gallon fiberglass pill-style pump out tank designed for deep burial depths up to 2.14m (7ft). The lightweight fiberglass construction provides a durable, corrosion-resistant, and high-strength structure that requires virtually zero-maintenance.

## MARKETS & APPLICATIONS



**RESIDENTIAL**



**COMMERCIAL**



**AGRICULTURAL**



**MINING**

[WWW.CARLSONCOMPOSITES.COM](http://WWW.CARLSONCOMPOSITES.COM)

PHONE: 1.204.233.0671

FAX: 1.204.233.6938

EMAIL: [info@carlsoncomposites.com](mailto:info@carlsoncomposites.com)