

CECPIL-1250IG-5S.6

1250 Gallon Pill Style Siphon Tank
Product Specifications

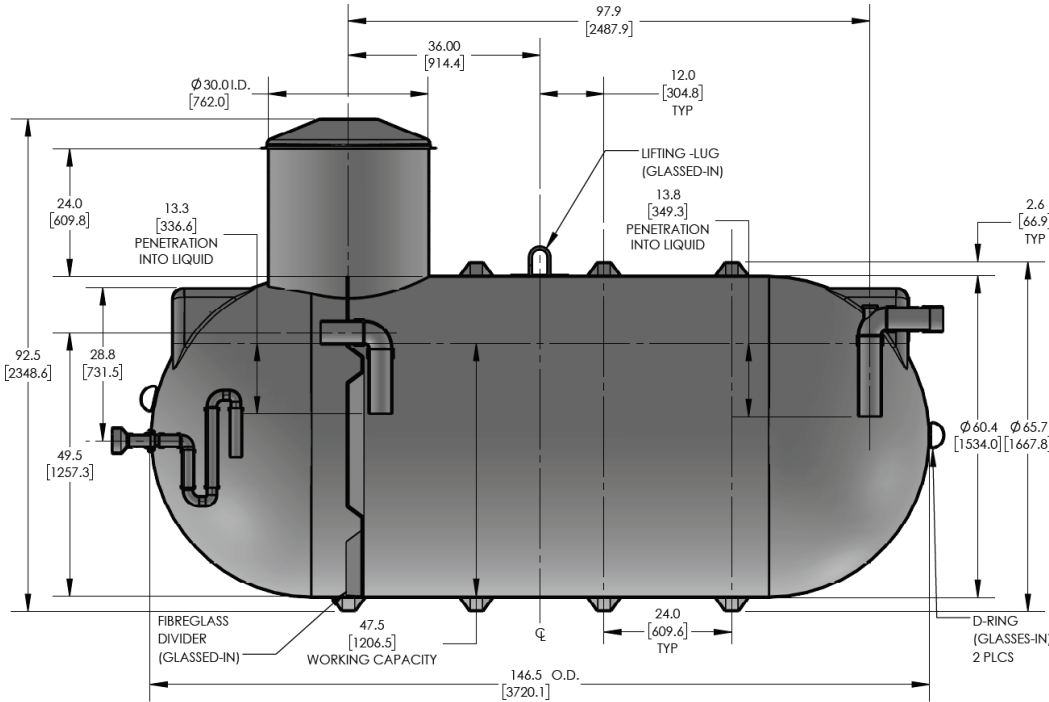

**ENGINEERED
COMPOSITES**



FEATURES AND BENEFITS

- CSA certified design and construction
- Corrosion resistant
- 100% neat resin construction
- Virtually maintenance-free
- External gelcoat for increased protection
- 30" wide easy-access manway
- Includes 4" standard ABS inlet
- Standard 10-year limited warranty

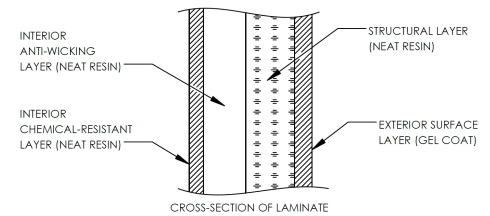

KEY SPECIFICATIONS

| | | |
|-----------------|--------------------|--------------|
| Nominal volume | 1,250 imp. gallons | 5,682 litres |
| Septic volume | 864 imp. gallons | 3,927 litres |
| Effluent volume | 242 imp. gallons | 1,100 litres |
| Overall length | 146.4 in | 3,718 mm |
| Approx. weight | 466 lbs | 211 kg |

The CECPIL-1250IG-5S.6 product is a CSA-approved 1250 imp. gallon fiberglass pill-style siphon tank designed for shallow burial depths up to 0.6m (2ft). The lightweight fiberglass construction provides a durable, corrosion-resistant, and high-strength structure that requires virtually zero-maintenance.

MARKETS & APPLICATIONS



RESIDENTIAL



COMMERCIAL



AGRICULTURAL



MINING

AVAILABLE OPTIONS

- Additional fittings & connections
- Manway extensions
- Lockable manway cover
- Hinged manway cover
- Polylok effluent filter
- Double-walled construction
- Insulated or heat-traced
- NSF potable water lining
- Full customization & engineering