

# CECPIL-1250IG-5W.9

1250 Gallon Pill Style Water Tank  
Product Specifications

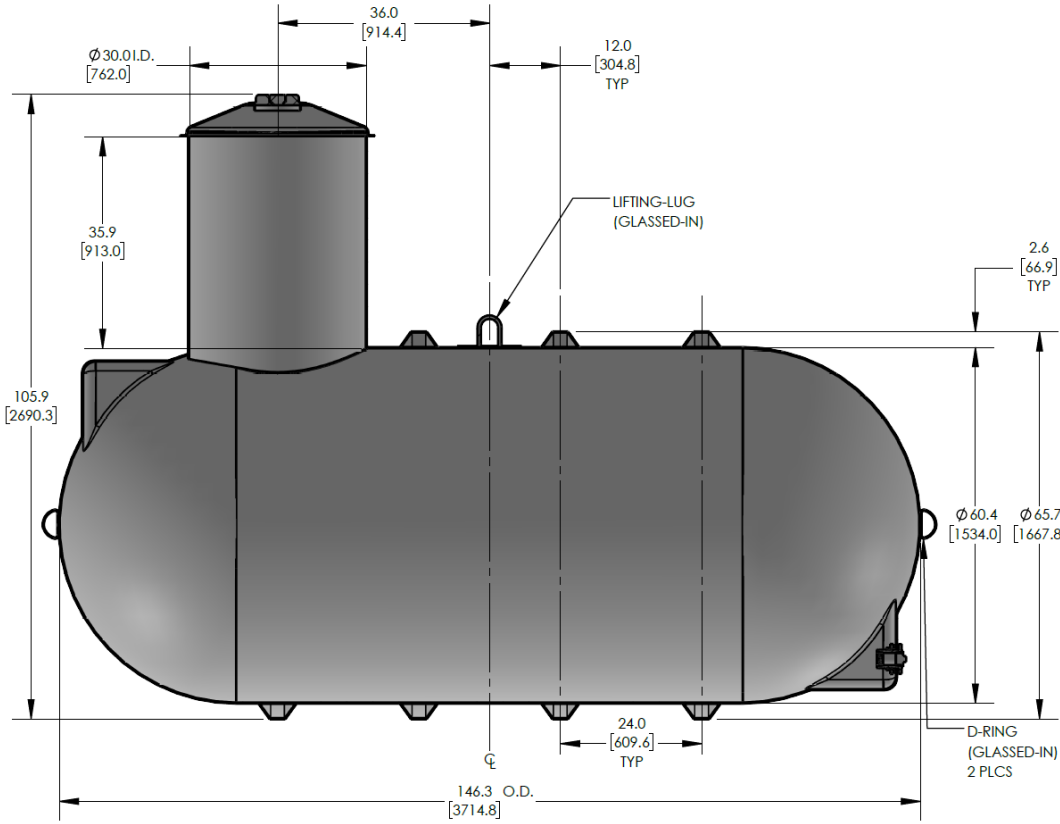

**ENGINEERED  
COMPOSITES**



## FEATURES AND BENEFITS

CSA certified design and construction

Corrosion resistant

100% neat resin construction

Virtually maintenance-free

External gelcoat for increased protection

30" wide easy-access manway

Standard 10-year limited warranty

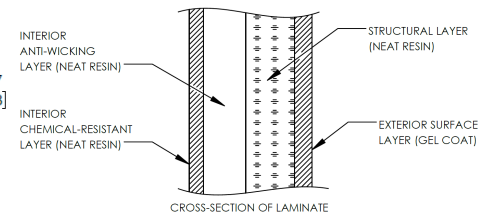

## KEY SPECIFICATIONS

Nominal volume	1,250 imp. gallons	5,682 litres
Useable volume	1,291 imp. gallons	5,869 litres
Overall length	146.3 in	3,715 mm
Approx. weight	407 lbs	185 kg

The CECPIL-1250IG-5W.9 product is a CSA-approved 1250 imp. gallon fiberglass pill-style water tank designed for burial depths up to 0.9m (3ft). The lightweight fiberglass construction provides a durable, corrosion-resistant, and high-strength structure that requires virtually zero-maintenance.

## MARKETS & APPLICATIONS



RESIDENTIAL



COMMERCIAL



AGRICULTURAL



MINING

## AVAILABLE OPTIONS

- Additional fittings & connections
- Manway extensions
- Lockable manway cover
- Hinged manway cover
- Double-walled construction
- Insulated or heat-traced
- NSF potable water lining
- Full customization & engineering