

CECPIL-3000IG-BP2.14

3000 Gallon Pill Style Pumpout Tank
Product Specifications

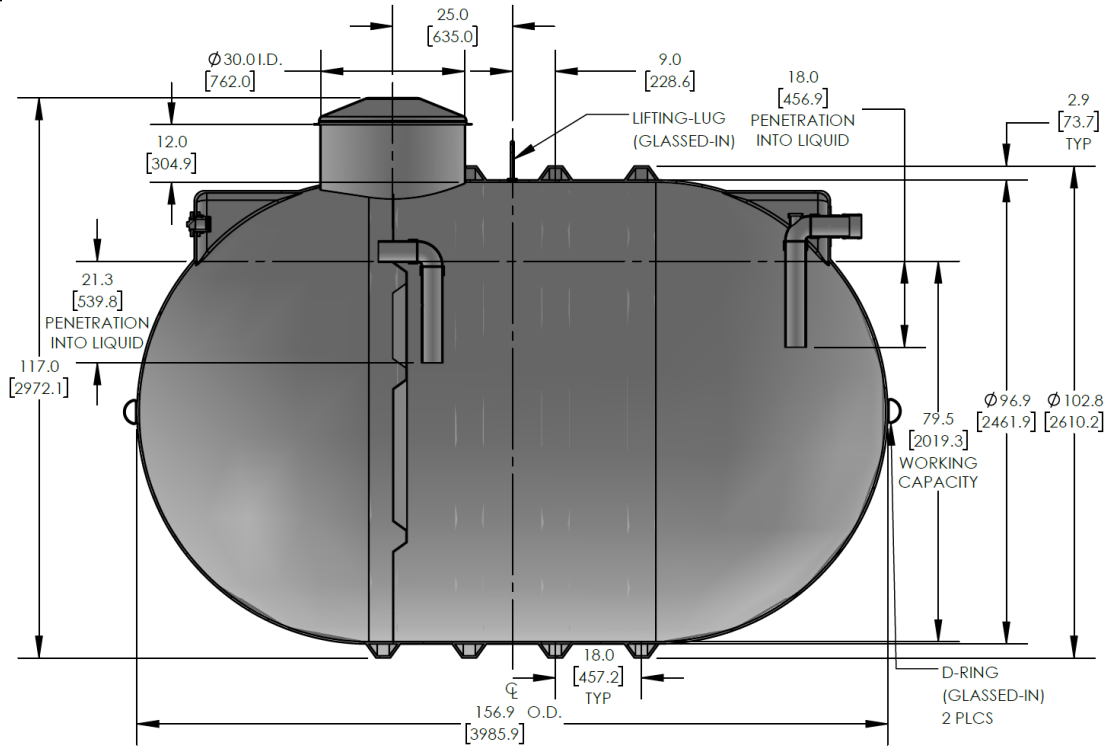

**ENGINEERED
COMPOSITES**



FEATURES AND BENEFITS

- CSA certified design and construction
- Corrosion resistant
- 100% neat resin construction
- Virtually maintenance-free
- External gelcoat for increased protection
- 30" wide easy-access manway
- Includes 4" standard ABS inlet
- Standard 10-year limited warranty

The CECPIL-3000IG-8P2.14 product is an 8-ft diameter CSA-certified 3000 imp. gallon fiberglass pill-style pumpout tank designed for burial depths up to 2.14m (7ft). The lightweight fiberglass construction provides a durable, corrosion-resistant, and high-strength structure that requires virtually zero-maintenance.

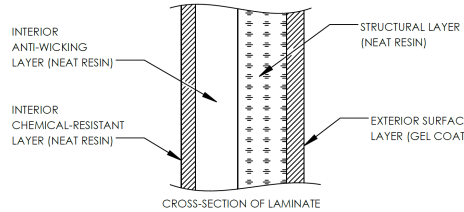

KEY SPECIFICATIONS

Nominal volume	3,000 imp. gallons	13,638 litres
Septic volume	2,040 imp. gallons	9,274 litres
Effluent volume	885 imp. gallons	4,023 litres
Overall length	156.9 in	3,985 mm
Approx. weight	1,575 lbs	714 kg

AVAILABLE OPTIONS

- Additional fittings & connections
- Manway extensions
- Lockable manway cover
- Hinged manway cover
- Polylok effluent filter
- Double-walled construction
- Insulated or heat-traced
- NSF potable water lining
- Full customization & engineering

MARKETS & APPLICATIONS



RESIDENTIAL



COMMERCIAL



AGRICULTURAL



MINING

WWW.CARLSONCOMPOSITES.COM

PHONE: 1.204.233.0671

FAX: 1.204.233.6938

EMAIL: info@carlsoncomposites.com