

CECPIL-4000IG-BT2.14

4000 Gallon Pill Style Trickle Tank
Product Specifications

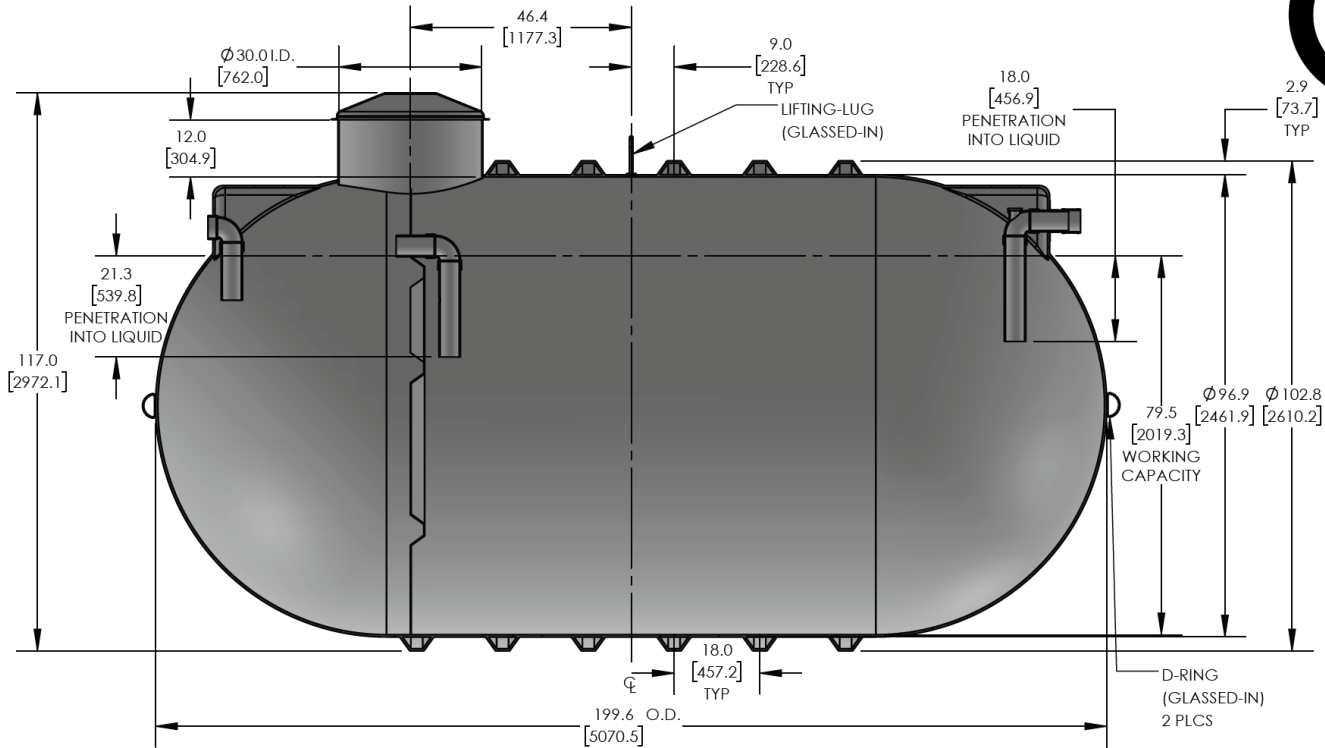

**ENGINEERED
COMPOSITES**



FEATURES AND BENEFITS

- CSA certified design and construction
- Corrosion resistant
- 100% neat resin construction
- Virtually maintenance-free
- External gelcoat for increased protection
- 30" wide easy-access manway
- Includes 4" standard ABS inlet
- Standard 10-year limited warranty

The CECPIL-4000IG-8T2.14 product is an 8-ft diameter CSA-certified 4000 imp. gallon fiberglass pill-style trickle tank designed for burial depths up to 2.14m (7ft). The lightweight fiberglass construction provides a durable, corrosion-resistant, and high-strength structure that requires virtually zero-maintenance.



KEY SPECIFICATIONS

Nominal volume	4,000 imp. gallons	18,185 litres
Septic volume	2,980 imp. gallons	13,547 litres
Effluent volume	885 imp. gallons	4,023 litres
Overall length	197.6 in	5,019 mm
Approx. weight	2,025 lbs	918 kg

AVAILABLE OPTIONS

- Additional fittings & connections
- Manway extensions
- Lockable manway cover
- Hinged manway cover
- Polylok effluent filter
- Double-walled construction
- Insulated or heat-traced
- NSF potable water lining
- Full customization & engineering

MARKETS & APPLICATIONS



RESIDENTIAL



COMMERCIAL



AGRICULTURAL



MINING