

# CECPIL-7500IG-10P.6

7500 Gallon Pill Style Pumpout Tank  
Product Specifications

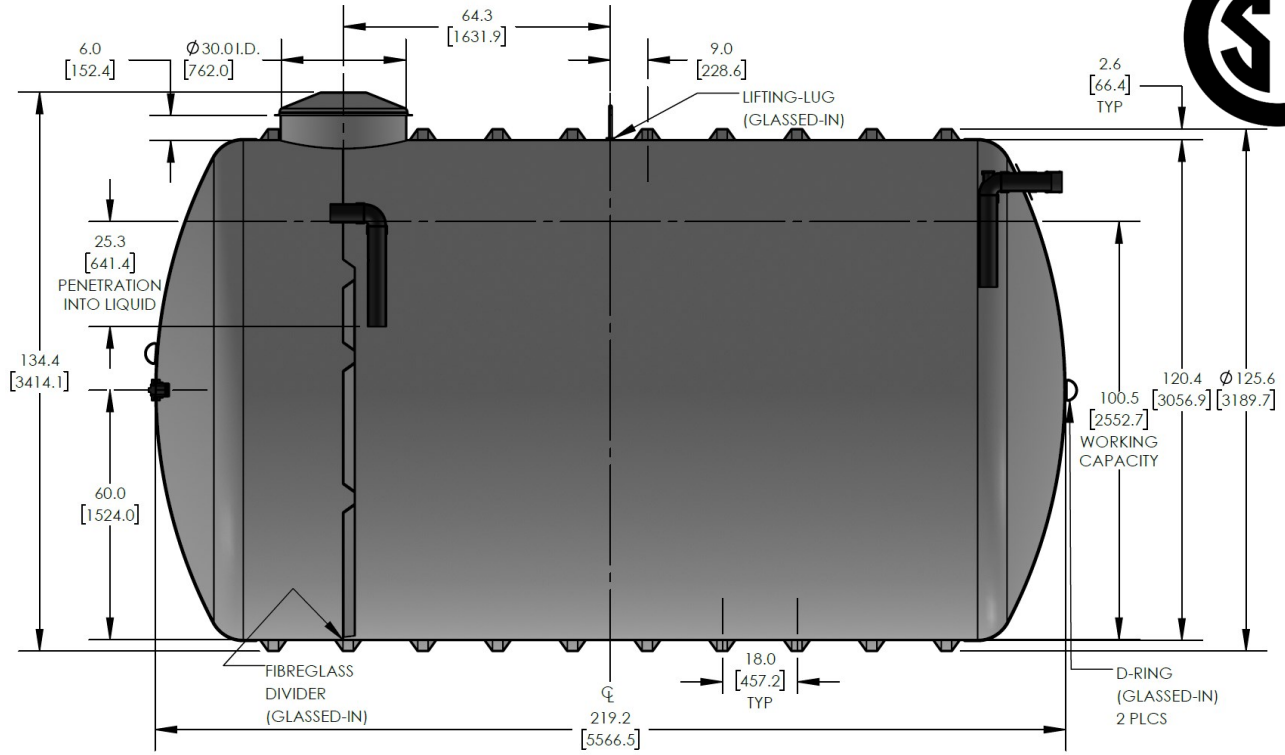

**ENGINEERED  
COMPOSITES**



## FEATURES AND BENEFITS

- CSA certified design and construction
- Corrosion resistant
- 100% neat resin construction
- Virtually maintenance-free
- External gelcoat for increased protection
- 30" wide easy-access manway
- Includes 4" standard ABS inlet
- Standard 10-year limited warranty

The CECPIL-7500IG-10P.6 product is an 10-ft diameter CSA-certified 7500 imp. gallon fiberglass pill-style pumpout tank designed for burial depths up to 0.6m (2ft). The lightweight filament wound fiberglass construction provides a durable, corrosion-resistant, and high-strength structure that requires virtually zero-maintenance.



## KEY SPECIFICATIONS

Nominal volume	7,500 imp. gallons	34,088 litres
Septic volume	6,052 imp. gallons	27,513 litres
Effluent volume	1,366 imp. gallons	6,210 litres
Overall length	219.2 in	5,568 mm
Approx. weight	1,718 lbs	779 kg

## AVAILABLE OPTIONS

- Additional fittings & connections
- Manway extensions
- Lockable manway cover
- Hinged manway cover
- Polylok effluent filter
- Double-walled construction
- Insulated or heat-traced
- NSF potable water lining
- Full customization & engineering

## MARKETS & APPLICATIONS



RESIDENTIAL



COMMERCIAL



AGRICULTURAL



MINING

WWW.CARLSONCOMPOSITES.COM

PHONE: 1.204.233.0671

FAX: 1.204.233.6938

EMAIL: info@carlsoncomposites.com