

# CECPIL-7500IG-10W.6

7500 Gallon Pill Style Water Tank  
Product Specifications

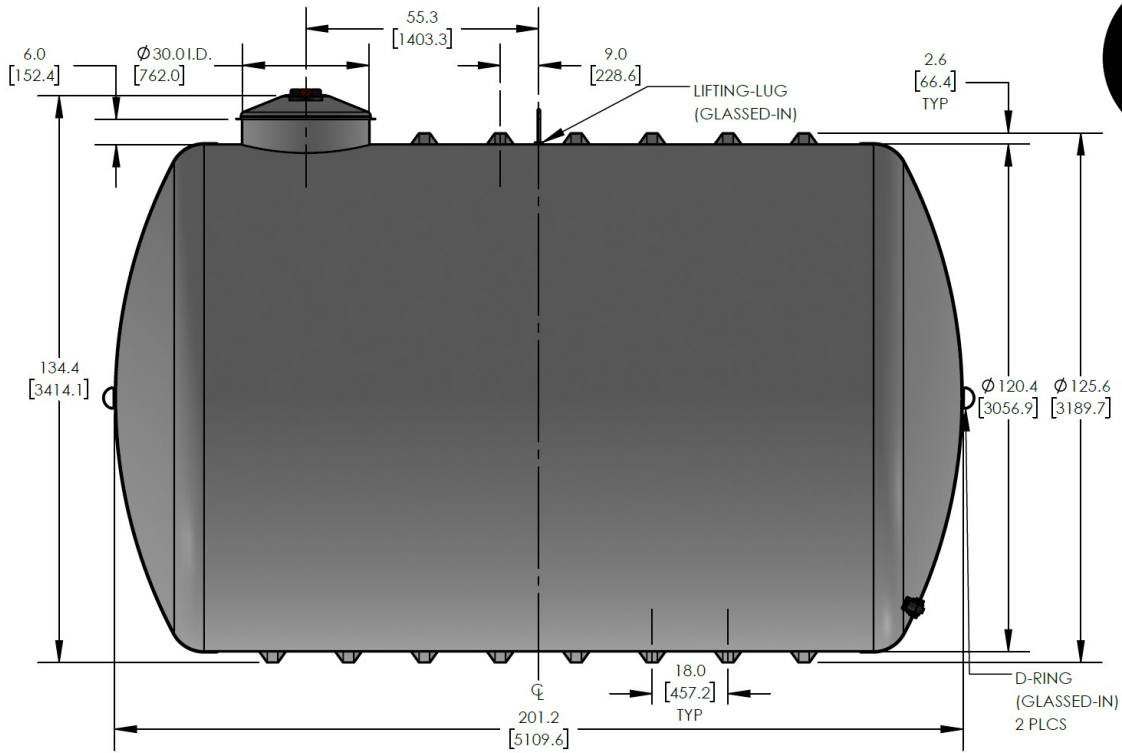

**ENGINEERED  
COMPOSITES**



## FEATURES AND BENEFITS

- CSA certified design and construction
- Corrosion resistant
- 100% neat resin construction
- Virtually maintenance-free
- External gelcoat for increased protection
- 30" wide easy-access manway
- Includes standard bulkhead outlet drain
- Standard 10-year limited warranty

The CECPIL-7500IG-10W.6 product is an 10-ft diameter CSA-certified 7500 imp. gallon fiberglass pill-style water tank designed for burial depths up to 0.6m (2ft). The lightweight filament wound fiberglass construction provides a durable, corrosion-resistant, and high-strength structure that requires virtually zero-maintenance.

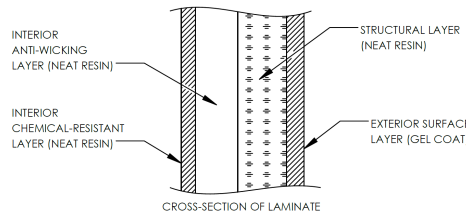

## KEY SPECIFICATIONS

Nominal volume	7,500 imp. gallons	34,088 litres
Septic volume	7,517 imp. gallons	34,173 litres
Effluent volume	-	-
Overall length	201.2 in	5,110 mm
Approx. weight	1,454 lbs	660 kg

## AVAILABLE OPTIONS

- Additional fittings & connections
- Manway extensions
- Lockable manway cover
- Hinged manway cover
- Polylok effluent filter
- Double-walled construction
- Insulated or heat-traced
- NSF potable water lining
- Full customization & engineering

## MARKETS & APPLICATIONS



RESIDENTIAL



COMMERCIAL



AGRICULTURAL



MINING

WWW.CARLSONCOMPOSITES.COM

PHONE: 1.204.233.0671

FAX: 1.204.233.6938

EMAIL: info@carlsoncomposites.com