

4

3

2

1

B

B

A

A

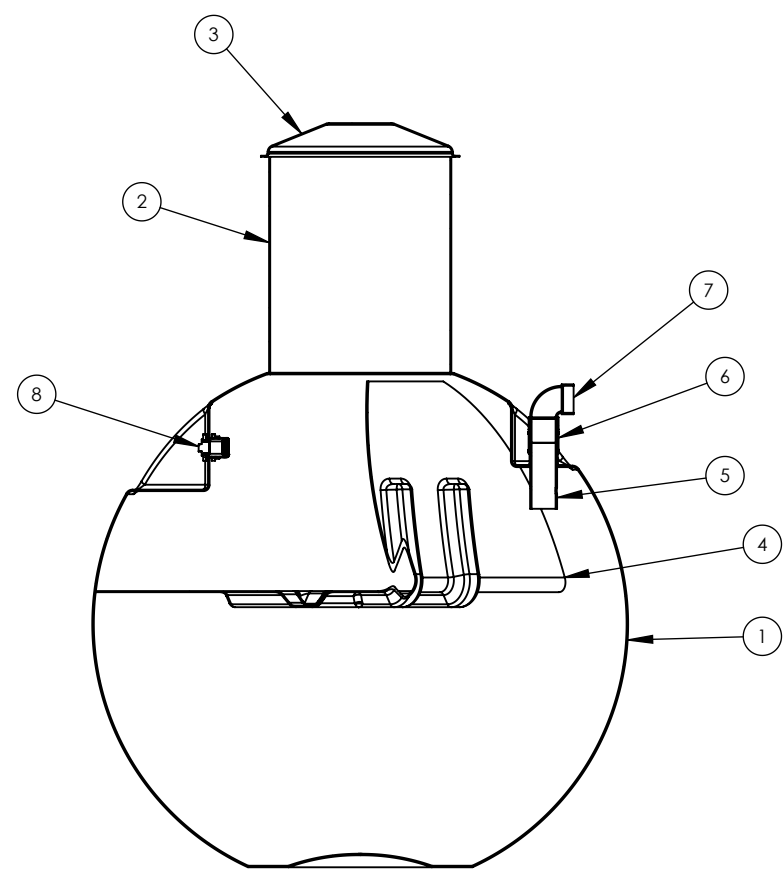

SECTION A-A

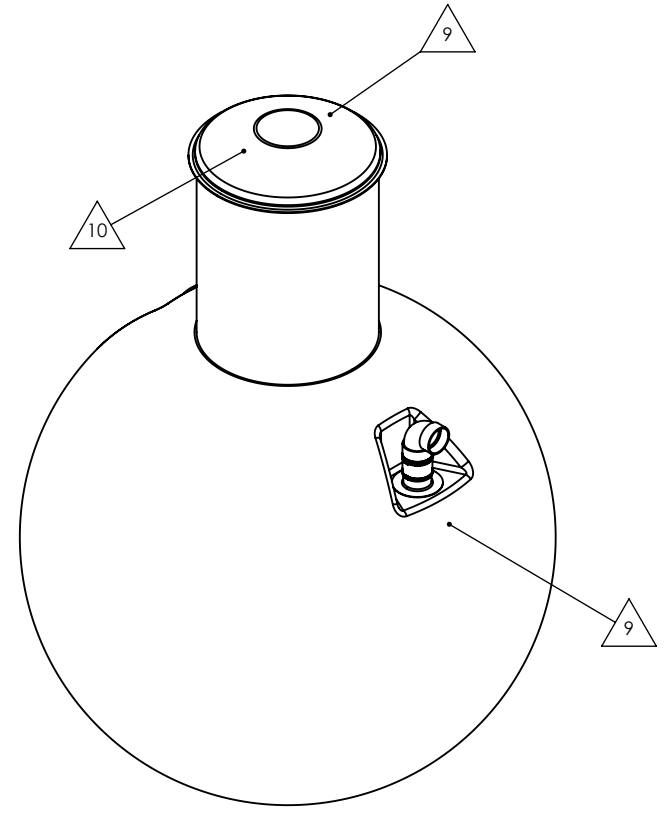
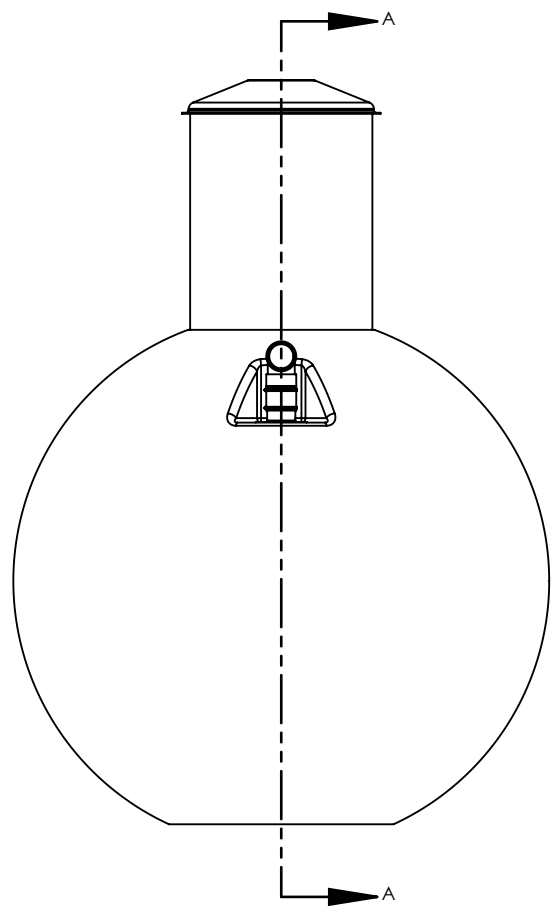

REFERENCE VIEW

ITEM NO.	PART NUMBER	QTY.
1	CECGLB-1000IG-P-TANK	1
2	CECGLB-30IN-MANWAY-COLLAR-36IN	1
3	CEC-30IN-MANWAY-LID	1
4	CEC-DIVIDER-1000IG	1
5	CEC-4INX8IN-LONG-FITTING ASSY	1
6	4IN-FERNCO-FLEX-CPLG	1
7	4INX90DEG-ABS-DWV-SHORT TURN ELBOW ASSY W 4IN EXTENSION	1
8	2IN-BULKHEAD-FITTING-ABS-WITH-PLUG	1

NOTES:

- 1. PUMP-OUT STYLE TANK
- 2. BURIAL DEPTH: UPTO 7FT (2.14 METERS) FROM GRADE TO TOP OF TANK
- 3. SPECIFIC GRAVITY: 1.1
- 4. RESIN: ORTHOPHTHALIC POLYESTER
- 5. MATERIAL: SPRAY CHOP HLU WITH 24 OZ WOVEN ROVING WHERE REQUIRED
- 6. DESIGNED AND CERTIFIED TO CSA B66 STANDARDS
- 7. OPTIONAL BELLED MANWAY EXTENSION LENGTHS AVAILABLE.
- 8. OPTIONAL MATERIAL FOR FITTINGS ABS, PVC, SDR AVAILBLE IN 4 INCH & 6 INCH CONFIGURATIONS.
- 9. TANK ID DECAL ATTACHED, AS SHOWN ON REFERENCE VIEW.
- 10. DANGER DO NOT ENTER DECAL WILL BE ATTACHED TO TOP OF LID, AS SHOWN ON REFERENCE VIEW



A		AZ		INITIAL RELEASE	
REV	DATE	DRN	CHK	DESCRIPTION	
DIMENSIONS ARE IN INCHES <i>UNLESS OTHERWISE SPECIFIED</i>				1035 MISSION STREET WINNIPEG, MB, CANADA R2J 0A4 (204) 233-0671 WWW.CARLSONCOMPOSITES.COM INFO@CARLSONCOMPOSITES.COM	
TOLERANCES: .X ±0.12 .XX ±0.06 .XXX ±0.03 ANGULAR ±0.5° UNLESS OTHERWISE SPECIFIED		MATERIAL: FRP		THE INFORMATION CONTAINED IN THIS DRAWING IS THE SOLE PROPERTY OF CARLSON ENGINEERED COMPOSITES INC.. ANY REPRODUCTION IN PART OR AS A WHOLE WITHOUT THE WRITTEN PERMISSION OF CARLSON ENGINEERED COMPOSITES INC. IS PROHIBITED.	
INITIAL RELEASE DATE:		CSA LABEL: CGR-4546P2.14 HGN-4546P2.14 CECGLB-1000IG-P2.14		JOB NO:	
DRAWN BY: AZ		DWG. NO. CECGLB-1000IG-P2.14		SIZE B REV A	
CHECKED BY:		SCALE: NTS		ESTIMATED WEIGHT: 437 LBS/198 KG	
				SHEET 1 OF 4	

4

3

2

1

4

3

2

1

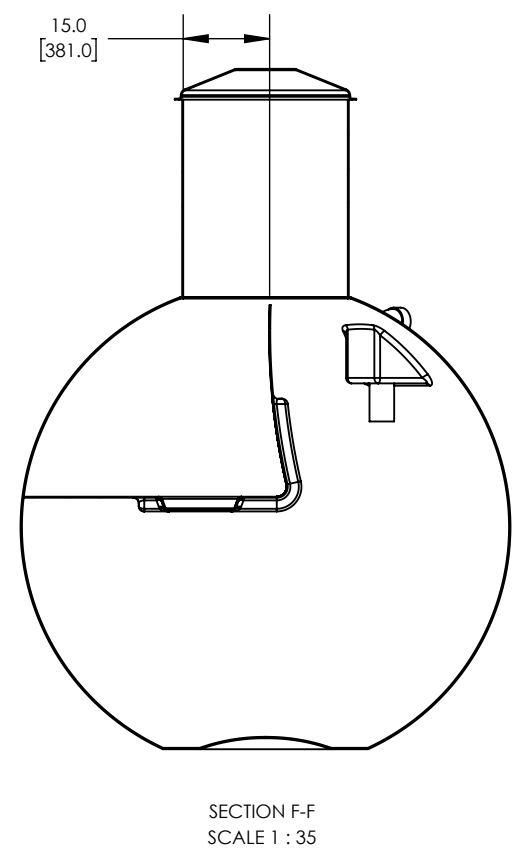
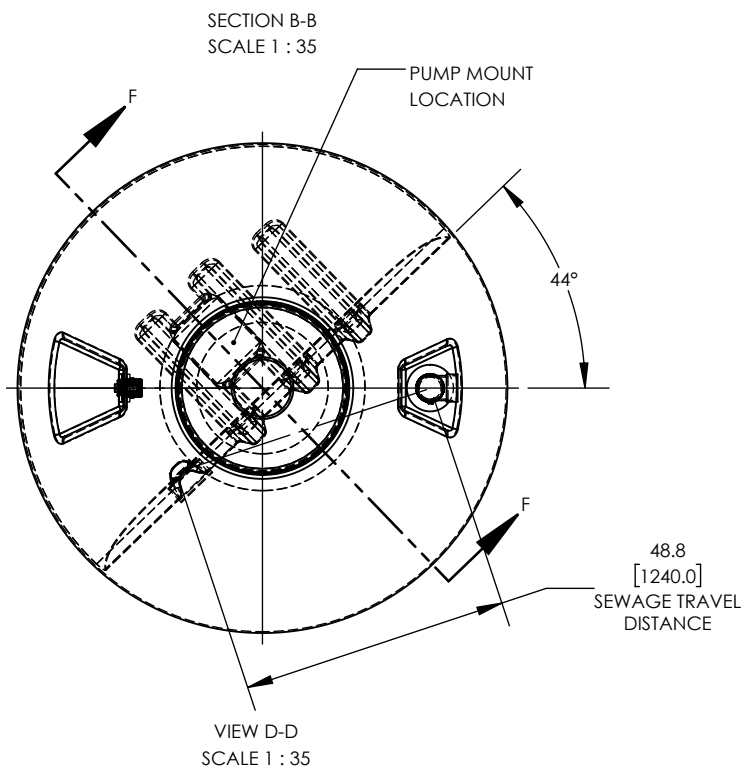
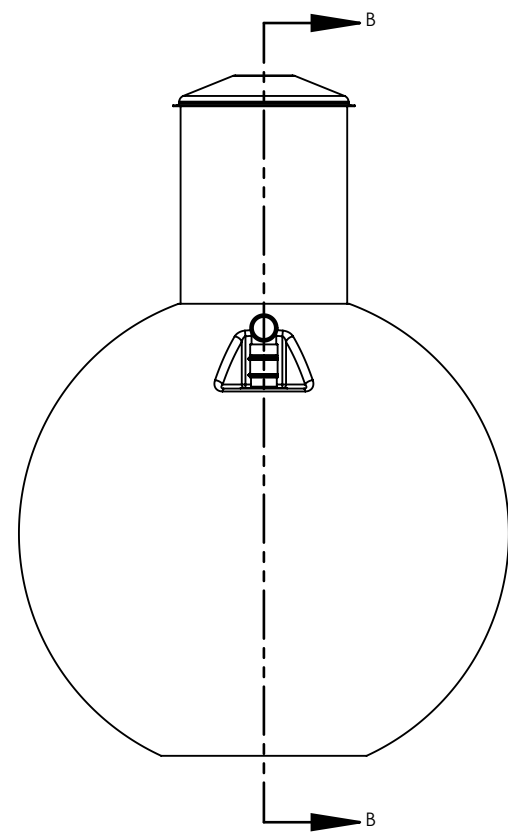
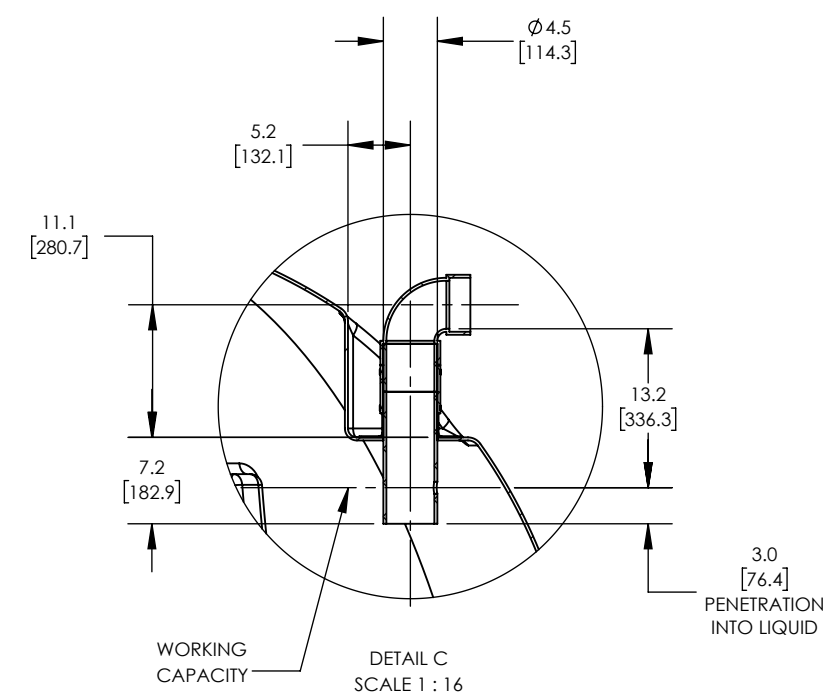
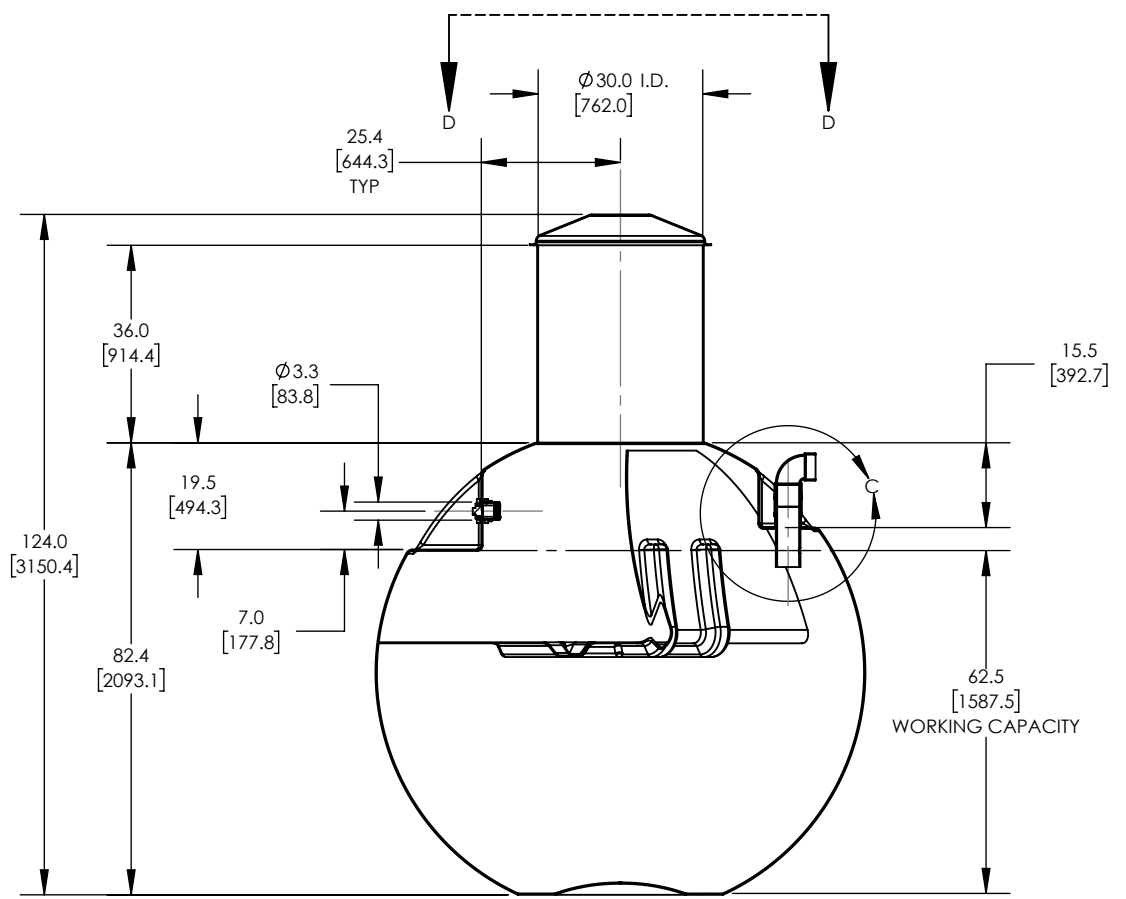

DIMENSIONS ARE IN INCHES
UNLESS OTHERWISE SPECIFIED

TOLERANCES:
 .X ±0.12
 .XX ±0.06
 .XXX ±0.03
 ANGULAR ±0.5°
 UNLESS OTHERWISE SPECIFIED

MATERIAL:
NTS

INITIAL RELEASE DATE:

DRAWN BY: AZ

CHECKED BY:

REV	DATE	DRN	CHK	DESCRIPTION
A		AZ		INITIAL RELEASE

1035 MISSION STREET
 WINNIPEG, MB, CANADA R2J 0A4
 (204) 233-0671
 WWW.CARLSONCOMPOSITES.COM
 INFO@CARLSONCOMPOSITES.COM

CARLSON ENGINEERED COMPOSITES

THE INFORMATION CONTAINED IN THIS DRAWING IS THE SOLE PROPERTY OF CARLSON ENGINEERED COMPOSITES INC.. ANY REPRODUCTION IN PART OR AS A WHOLE WITHOUT THE WRITTEN PERMISSION OF CARLSON ENGINEERED COMPOSITES INC. IS PROHIBITED.

CSA LABEL:	CGR-4546P2.14 HGN-4546P2.14 CECGLB-1000IG-P2.14	JOB NO:	
DWG. NO.	CECGLB-1000IG-P2.14	SIZE	REV
		B	A
SCALE: NTS	ESTIMATED WEIGHT: 437 LBS/198 KG	SHEET 2 OF 4	

4

3

2

1

B

B

A

A

4

3

2

1

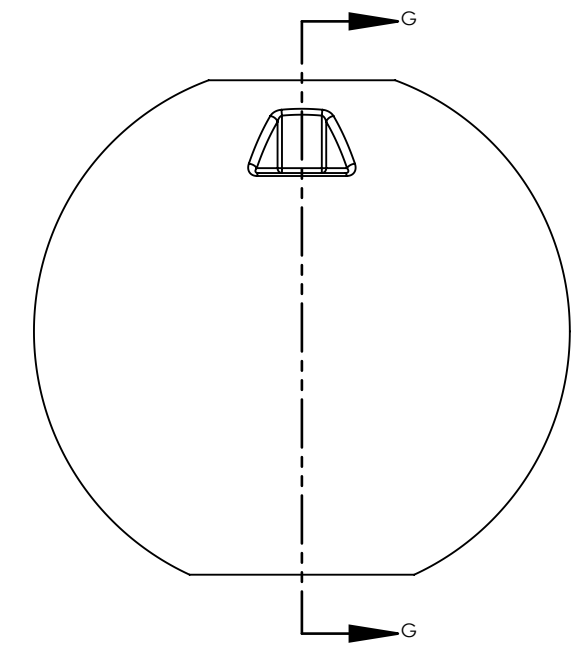
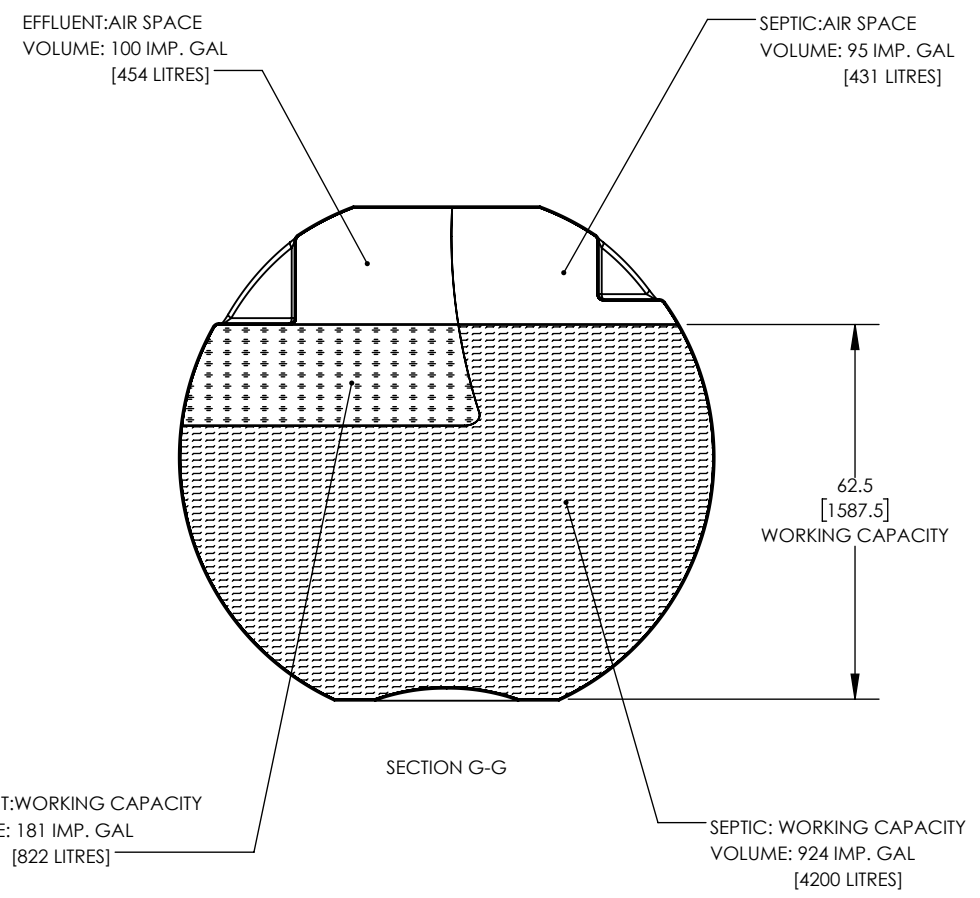

B

B

A

A

VOLUME TABLE

COMPARTMENT	WORKING CAPACITY		AIR SPACE		TOTAL	
	IMP. GAL	LITRES	IMP. GAL	LITRES	IMP. GAL	LITRES
SEPTIC	924	4200	95	431	1019	4631
EFFLUENT	181	822	100	454	281	1276
TOTAL TANK	1105	5022	195	885	1300	5907

DIMENSIONS ARE IN INCHES UNLESS OTHERWISE SPECIFIED

TOLERANCES:
.X ±0.12
.XX ±0.06
.XXX ±0.03
ANGULAR ±0.5°
UNLESS OTHERWISE SPECIFIED

MATERIAL: FRP

INITIAL RELEASE DATE:

DRAWN BY: AZ

CHECKED BY:

A		AZ		INITIAL RELEASE
REV	DATE	DRN	CHK	DESCRIPTION

1035 MISSION STREET
WINNIPEG, MB, CANADA R2J 0A4
(204) 233-0671
WWW.CARLSONCOMPOSITES.COM
INFO@CARLSONCOMPOSITES.COM

THE INFORMATION CONTAINED IN THIS DRAWING IS THE SOLE PROPERTY OF CARLSON ENGINEERED COMPOSITES INC.. ANY REPRODUCTION IN PART OR AS A WHOLE WITHOUT THE WRITTEN PERMISSION OF CARLSON ENGINEERED COMPOSITES INC. IS PROHIBITED.

CSA LABEL: CGR-4546P2.14
HGN-4546P2.14
CECGLB-1000IG-P2.14

JOB NO:

DWG. NO. CECGLB-1000IG-P2.14

SIZE B REV A

SCALE: NTS ESTIMATED WEIGHT: 437 LBS/198 KG

SHEET 3 OF 4

4

3

2

1