

4

3

2

1

ITEM NO.	PART NUMBER	QTY.
1	CECGLB-750IG-S-TANK-.6	1
2	CECGLB-30IN-MANWAY-COLLAR-24IN	1
3	CEC-30IN-MANWAY-LID	1
4	CECGLB-750DIVIDER	1
5	CEC-4INX10IN-LONG-FITTING-ASSY-W-1IN-HOLE	1
6	4IN-FERNCO-FLEX-CPLG	1
7	4INX90DEG-ABS-DWV-SHORT TURN ELBOW ASSY W 4IN EXTENSION	1
8	SIPHON ASSY	1

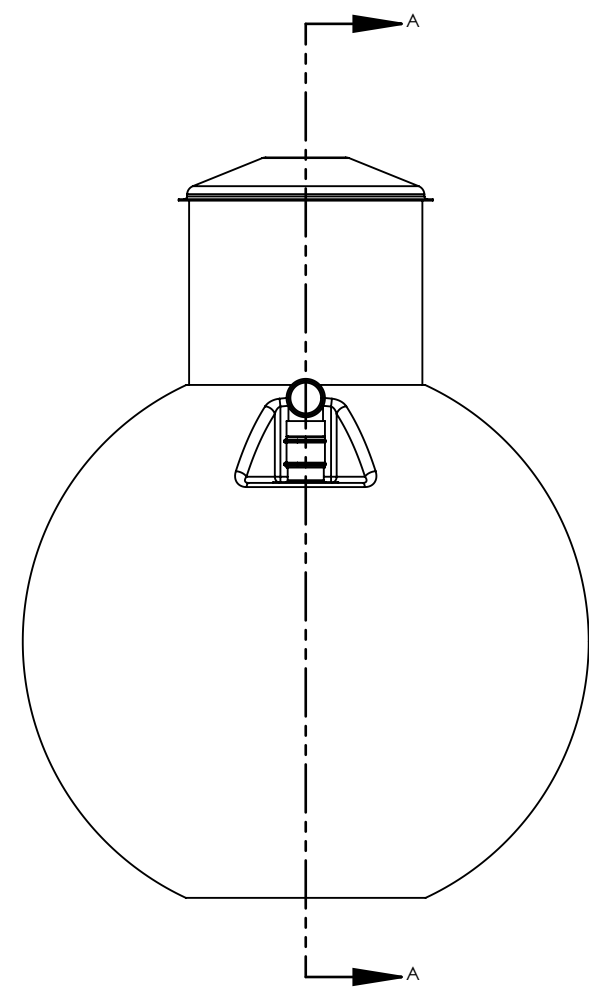
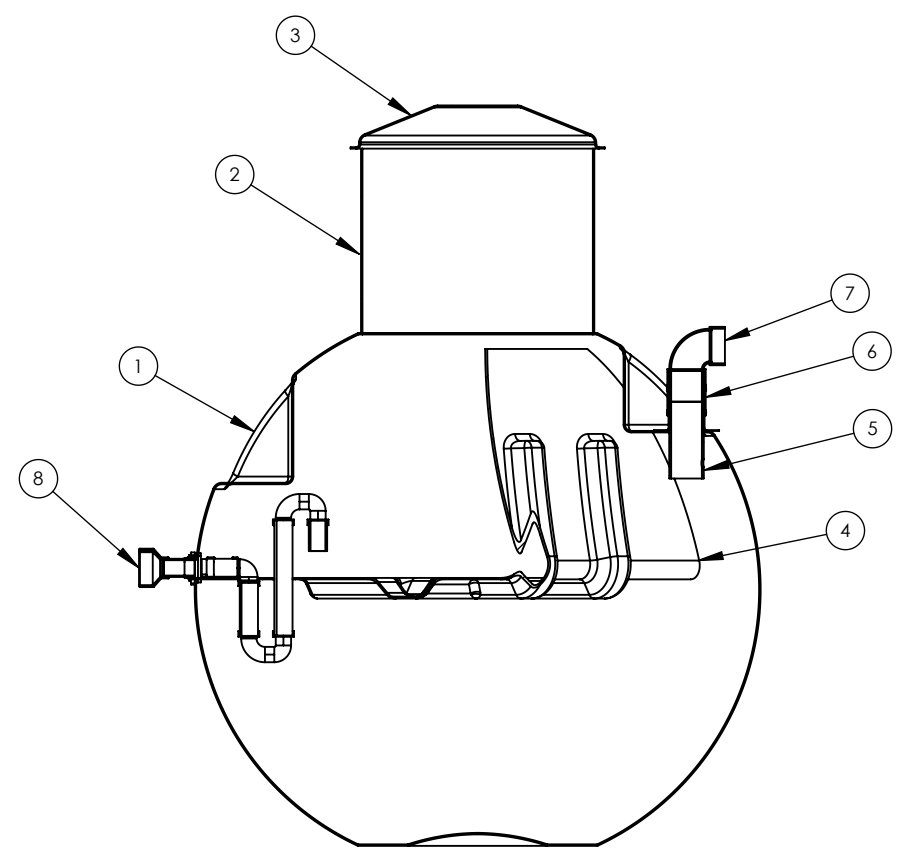

SECTION A-A
SCALE 1 : 25

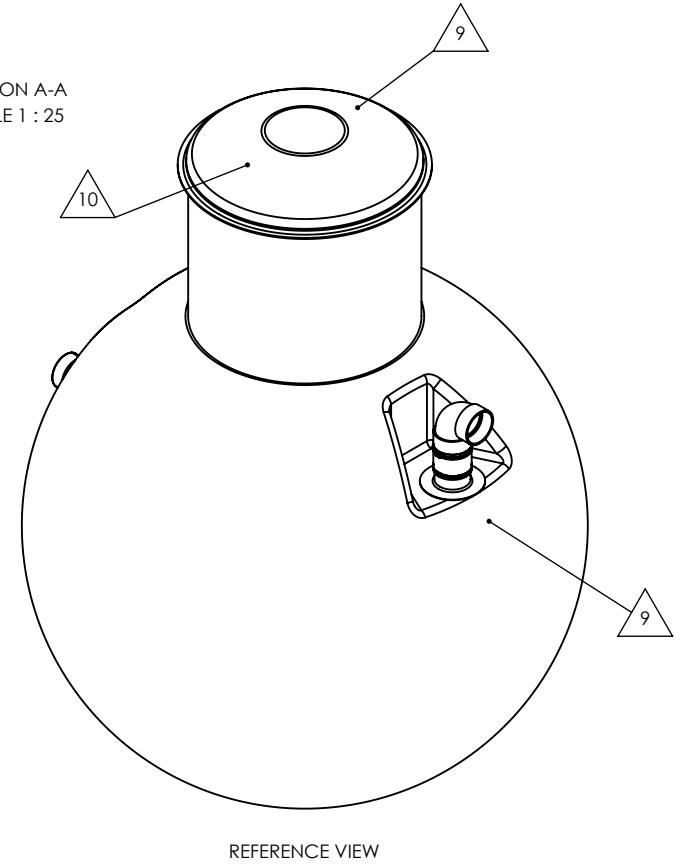

REFERENCE VIEW

NOTES:

1. SIPHON STYLE TANK.
 2. BURIAL DEPTH: UP TO 2FT (0.6 METERS) FROM GRADE TO TOP OF TANK.
 3. SPECIFIC GRAVITY: 1.1
 4. RESIN: ORTHOPHTHALIC POLYESTER.
 5. MATERIAL: SPRAY CHOP HLU WITH 24 OZ WOVEN ROVING WHERE REQUIRED.
 6. DESIGNED AND CERTIFIED TO CSA B66 STANDARDS.
 7. OPTIONAL BELLED MANWAY EXTENSION LENGTHS AVAILABLE.
 8. OPTIONAL MATERIAL FOR FITTINGS ABS, PVC, SDR AVAILBLE IN 4 INCH & 6 INCH CONFIGURATIONS.
- ⚠ TANK ID DECAL ATTACHED, AS SHOWN ON REFERENCE VIEW.
 ⚠ DANGER DO NOT ENTER DECAL WILL BE ATTACHED TO TOP OF LID, AS SHOWN ON REFERENCE VIEW



A		AZ		INITIAL RELEASE	
REV	DATE	DRN	CHK	DESCRIPTION	
DIMENSIONS ARE IN INCHES <i>UNLESS OTHERWISE SPECIFIED</i>		<p>1035 MISSION STREET WINNIPEG, MB, CANADA R2J 0A4 (204) 233-0671 WWW.CARLSONCOMPOSITES.COM INFO@CARLSONCOMPOSITES.COM</p>			
TOLERANCES: .X ±0.12 .XX ±0.06 .XXX ±0.03 ANGULAR ±0.5° <i>UNLESS OTHERWISE SPECIFIED</i>		THE INFORMATION CONTAINED IN THIS DRAWING IS THE SOLE PROPERTY OF CARLSON ENGINEERED COMPOSITES INC.. ANY REPRODUCTION IN PART OR AS A WHOLE WITHOUT THE WRITTEN PERMISSION OF CARLSON ENGINEERED COMPOSITES INC. IS PROHIBITED.			
MATERIAL: FRP		CSA LABEL: CGR-3410S.6 HGN-3410S.6 CECGLB-750IG-S.6		JOB NO:	
INITIAL RELEASE DATE:		DWG. NO. CECGLB-750IG-S.6		SIZE B	REV A
DRAWN BY: AZ	SCALE: NTS		ESTIMATED WEIGHT: 253 LBS/114 KG		SHEET 1 OF 4
CHECKED BY:					

4

3

2

1

B

B

A

A

4

3

2

1

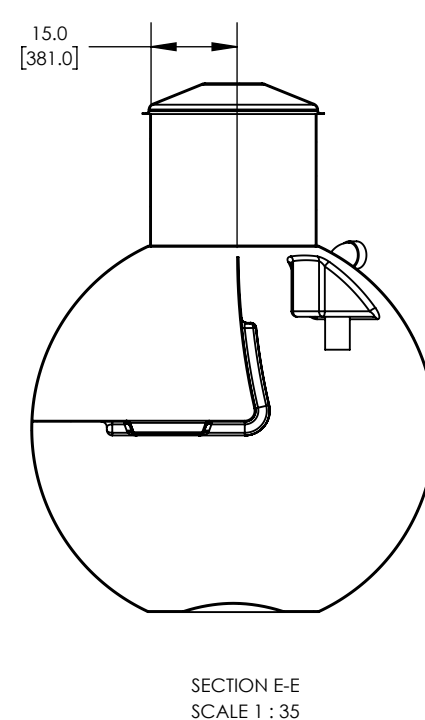
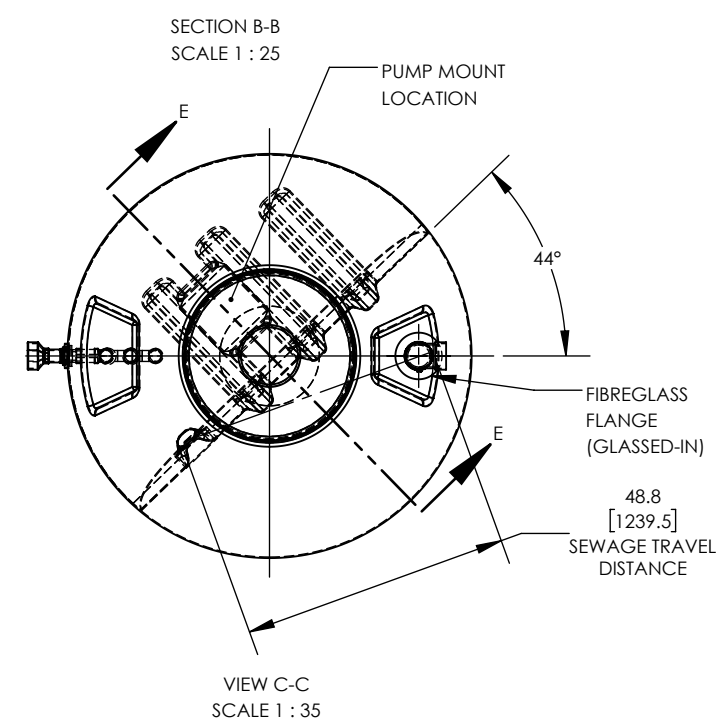
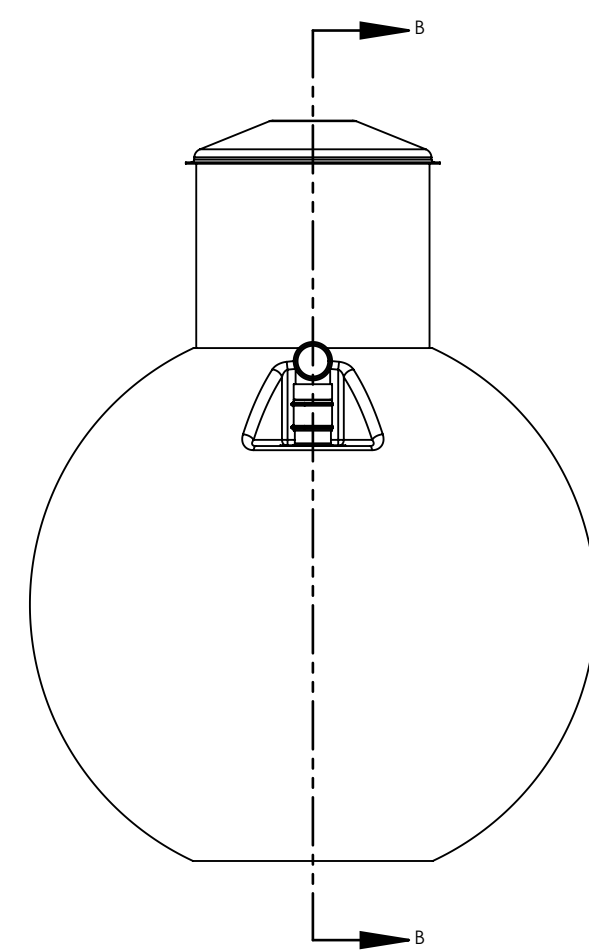
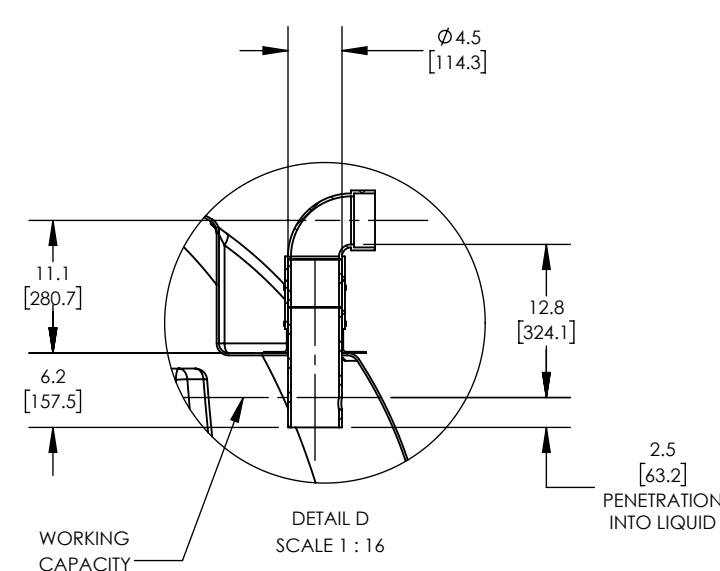
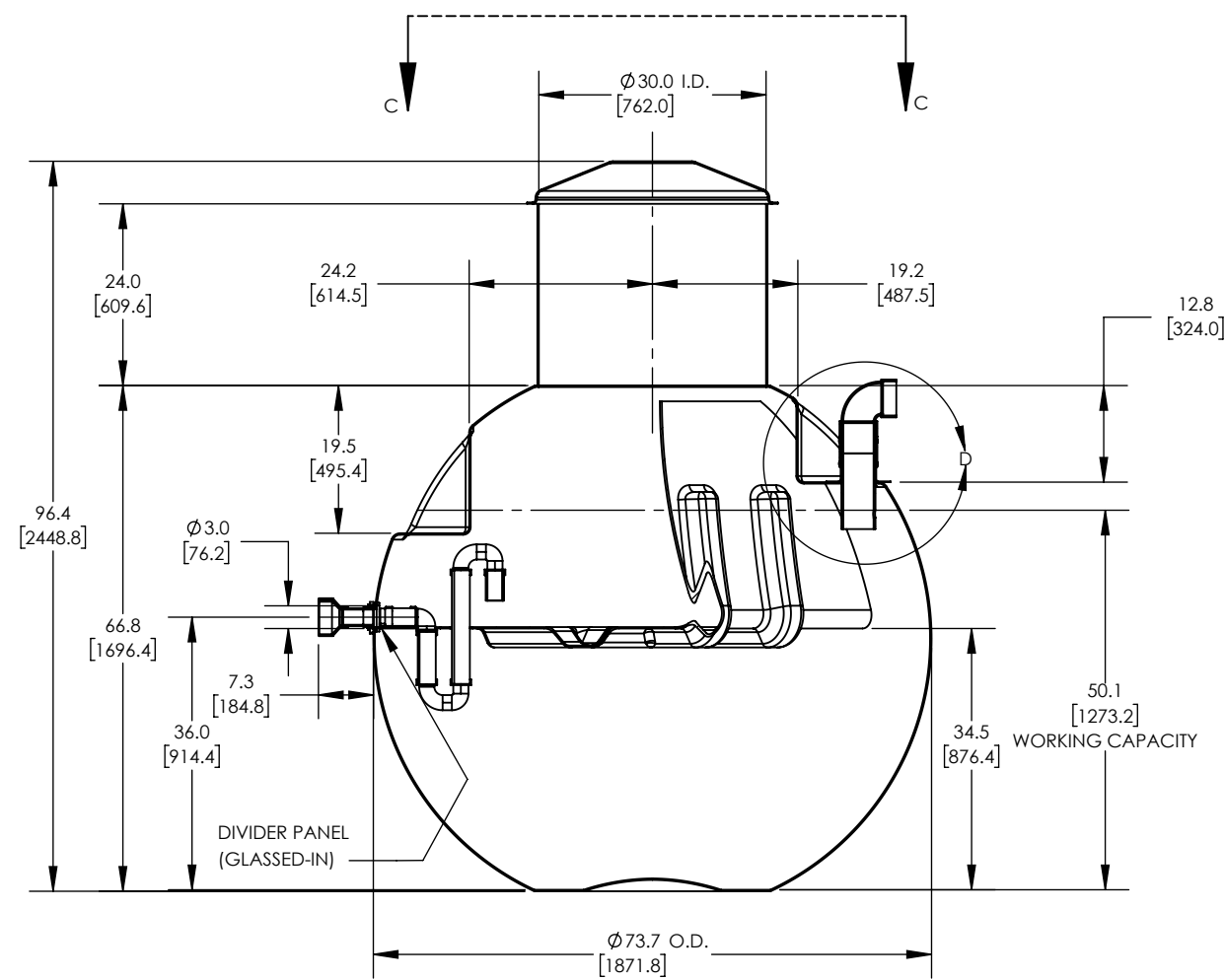

DIMENSIONS ARE IN INCHES
UNLESS OTHERWISE SPECIFIED

TOLERANCES:
 .X ±0.12
 .XX ±0.06
 .XXX ±0.03
 ANGULAR ±0.5°
 UNLESS OTHERWISE SPECIFIED

MATERIAL:
FRP

INITIAL RELEASE DATE:

DRAWN BY: AZ

CHECKED BY:

REV	DATE	DRN	CHK	DESCRIPTION
A		AZ		INITIAL RELEASE

1035 MISSION STREET
 WINNIPEG, MB, CANADA R2J 0A4
 (204) 233-0671
 WWW.CARLSONCOMPOSITES.COM
 INFO@CARLSONCOMPOSITES.COM

CARLSON ENGINEERED COMPOSITES

THE INFORMATION CONTAINED IN THIS DRAWING IS THE SOLE PROPERTY OF CARLSON ENGINEERED COMPOSITES INC.. ANY REPRODUCTION IN PART OR AS A WHOLE WITHOUT THE WRITTEN PERMISSION OF CARLSON ENGINEERED COMPOSITES INC. IS PROHIBITED.

CSA LABEL:	CGR-3410S.6 HGN-3410S.6 CECGLB-750IG-S.6	JOB NO:
DWG. NO.	CECGLB-750IG-S.6	SIZE B
SCALE: NTS	ESTIMATED WEIGHT: 253 LBS/114 KG	REV A
		SHEET 2 OF 4

4

3

2

1

B

B

A

A

4

3

2

1

EFFLUENT: AIR SPACE
VOLUME: 63 IMP. GAL
[287 LITRES]

SEPTIC: AIR SPACE
VOLUME: 58 IMP. GAL
[263 LITRES]

16.3
[413.7]
AIR SPACE

50.1
[1272.7]
WORKING CAPACITY

SECTION F-F
SCALE 1 : 25

EFFLUENT: WORKING CAPACITY
VOLUME: 117 IMP. GAL
[532 LITRES]

SEPTIC: WORKING CAPACITY
VOLUME: 488 IMP. GAL
[2219 LITRES]

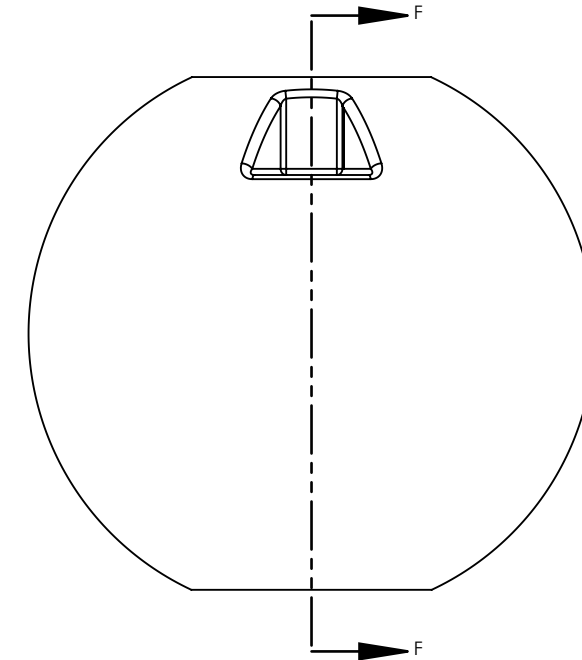

VOLUME TABLE

COMPARTMENT	WORKING CAPACITY		AIR SPACE		TOTAL	
	IMP. GAL	LITRES	IMP. GAL	LITRES	IMP. GAL	LITRES
SEPTIC	488	2219	58	263	546	2482
EFFLUENT	117	532	63	287	180	819
TOTAL TANK	605	2751	121	550	726	3301

DIMENSIONS ARE
IN INCHES
UNLESS OTHERWISE SPECIFIED

TOLERANCES:
.X ±0.12
.XX ±0.06
.XXX ±0.03
ANGULAR ±0.5°
UNLESS OTHERWISE SPECIFIED

MATERIAL:
FRP

INITIAL RELEASE DATE:

DRAWN BY: AZ

CHECKED BY:

REV	DATE	DRN	CHK	DESCRIPTION	INITIAL RELEASE
				1035 MISSION STREET WINNIPEG, MB, CANADA R2J 0A4 (204) 233-0671 WWW.CARLSONCOMPOSITES.COM INFO@CARLSONCOMPOSITES.COM	
				THE INFORMATION CONTAINED IN THIS DRAWING IS THE SOLE PROPERTY OF CARLSON ENGINEERED COMPOSITES INC.. ANY REPRODUCTION IN PART OR AS A WHOLE WITHOUT THE WRITTEN PERMISSION OF CARLSON ENGINEERED COMPOSITES INC. IS PROHIBITED.	
CSA LABEL:			CGR-3410S.6		JOB NO:
			HGN-3410S.6		
			CECGLB-750IG-S.6		
DWG. NO.			CECGLB-750IG-S.6		SIZE B
					REV A
SCALE: NTS		ESTIMATED WEIGHT: 253 LBS/114 KG		SHEET 3 OF 4	

4

3

2

1