

4

3

2

1

ITEM NO.	PART NUMBER	QTY.
1	CECGLB-750IG-T-TANK-2.14	1
2	CECGLB-30IN-MANWAY-COLLAR-36IN	1
3	CEC-30IN-MANWAY-LID	1
4	CECGLB-750DIVIDER	1
5	CEC-4INX10IN-LONG-FITTING-ASSY-W-1IN-HOLE	2
6	4INX90DEG-ABS-DWV-SHORT TURN ELBOW ASSY W 4IN EXTENSION	2
7	4IN-FERNCO-FLEX-CPLG	2

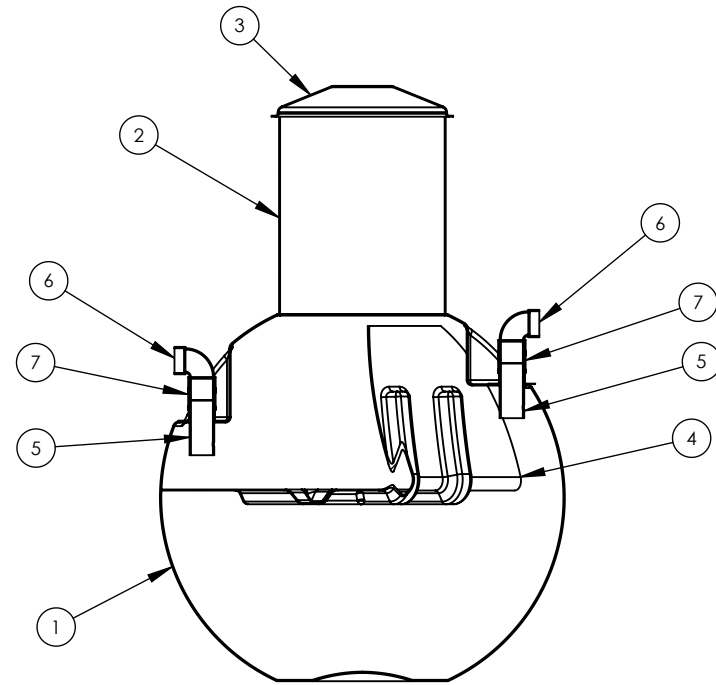

SECTION A-A
SCALE 1 : 35

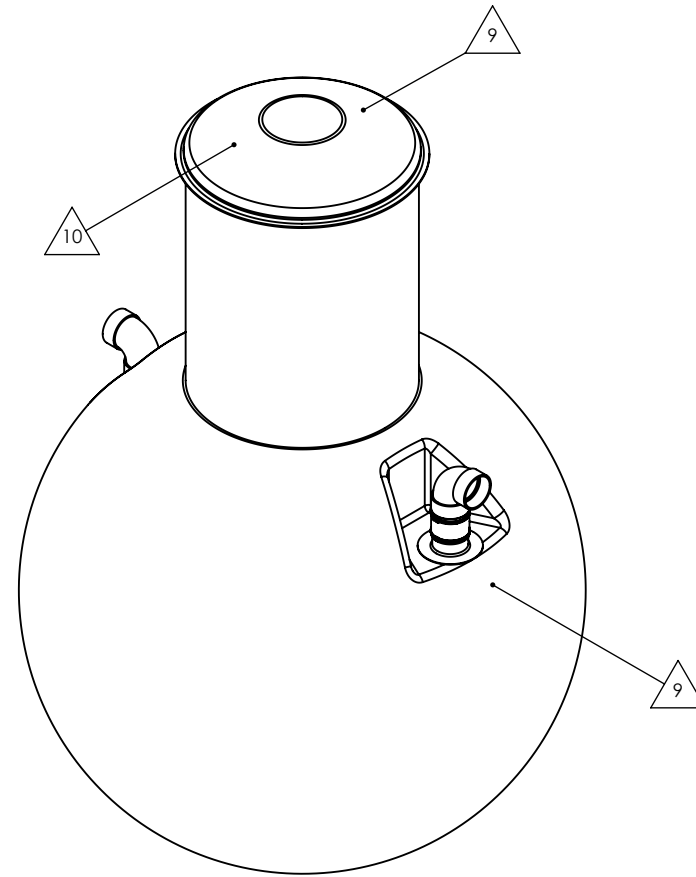
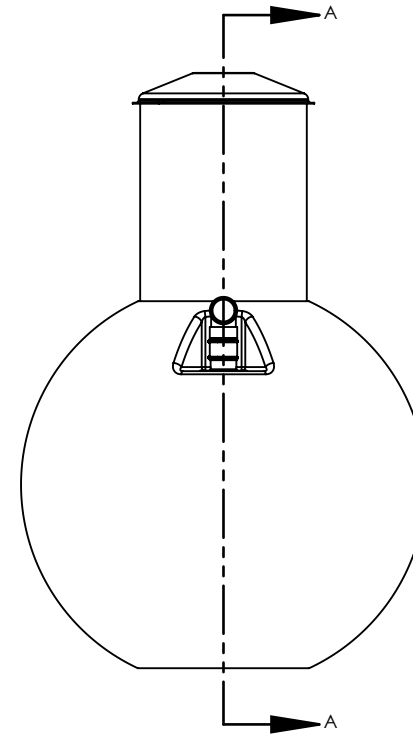

REFERENCE VIEW

NOTES:

1. TRICKLE STYLE STYLE TANK
2. BURIAL DEPTH: UPTO 7FT (2.14 METERS) FROM GRADE TO TOP OF TANK
3. SPECIFIC GRAVITY: 1.1
4. RESIN: ORTHOPHTHALIC POLYESTER
5. MATERIAL: SPRAY CHOP HLU WITH 24 OZ WOVEN ROVING WHERE REQUIRED
6. DESIGNED AND CERTIFIED TO CSA B66 STANDARDS
7. OPTIONAL BELLED MANWAY EXTENSION LENGTHS AVAILABLE.
8. OPTIONAL MATERIAL FOR FITTINGS ABS, PVC, SDR AVAILBLE IN 4 INCH & 6 INCH CONFIGURATIONS.
9. TANK ID DECAL ATTACHED, AS SHOWN ON REFERENCE VIEW.
10. DANGER DO NOT ENTER DECAL WILL BE ATTACHED TO TOP OF LID, AS SHOWN ON REFERENCE VIEW



REV	DATE	DRN	CHK	DESCRIPTION	INITIAL RELEASE
A		AZ			INITIAL RELEASE

<p>DIMENSIONS ARE IN INCHES <i>UNLESS OTHERWISE SPECIFIED</i></p>		<p>1035 MISSION STREET WINNIPEG, MB, CANADA R2J 0A4 (204) 233-0671 WWW.CARLSONCOMPOSITES.COM INFO@CARLSONCOMPOSITES.COM</p>	<p>JOB NO:</p>
<p>TOLERANCES: .X ±0.12 .XX ±0.06 .XXX ±0.03 ANGULAR ±0.5° UNLESS OTHERWISE SPECIFIED</p>			
<p>MATERIAL: FRP</p>		<p>CSA LABEL: CGR-3410T2.14 HGN-3410T2.14 CECGLB-750IG-T2.14</p>	<p>SIZE B</p>
<p>INITIAL RELEASE DATE:</p>			
<p>DRAWN BY: AZ</p>		<p>DWG. NO. CECGLB-750IG-T2.14</p>	<p>REV A</p>
<p>CHECKED BY:</p>			
<p>SHEET 1 OF 4</p>			

4

3

2

1

4

3

2

1

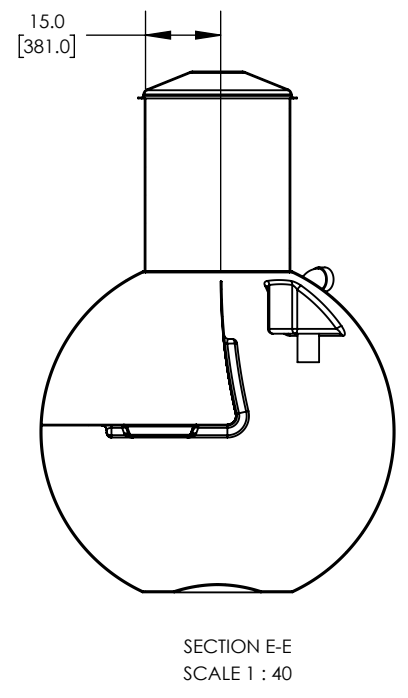
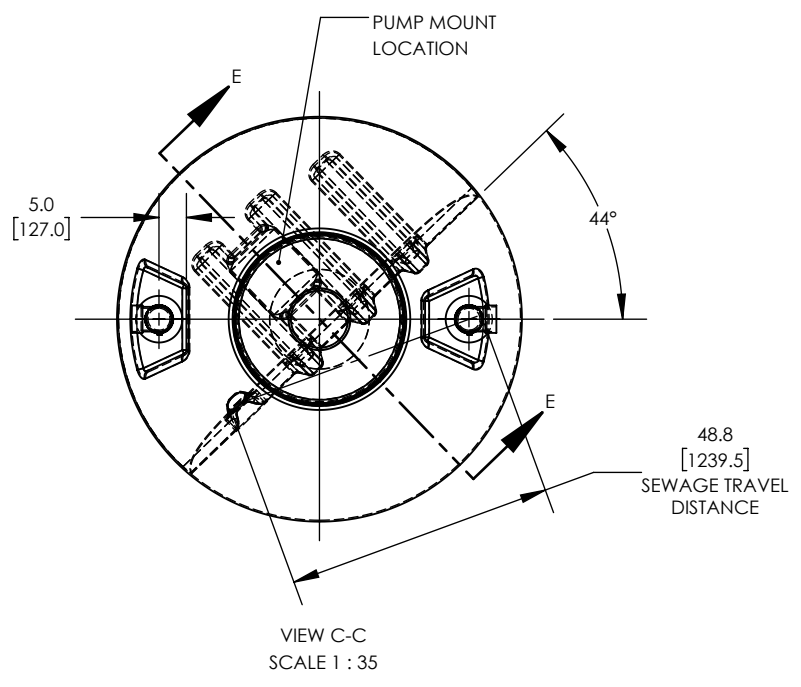
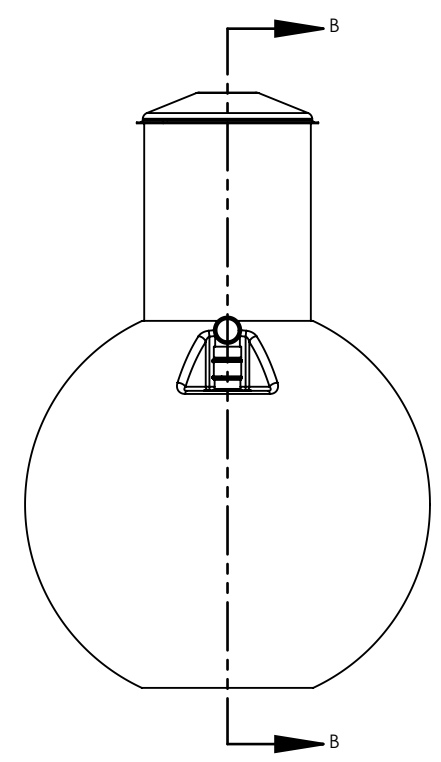
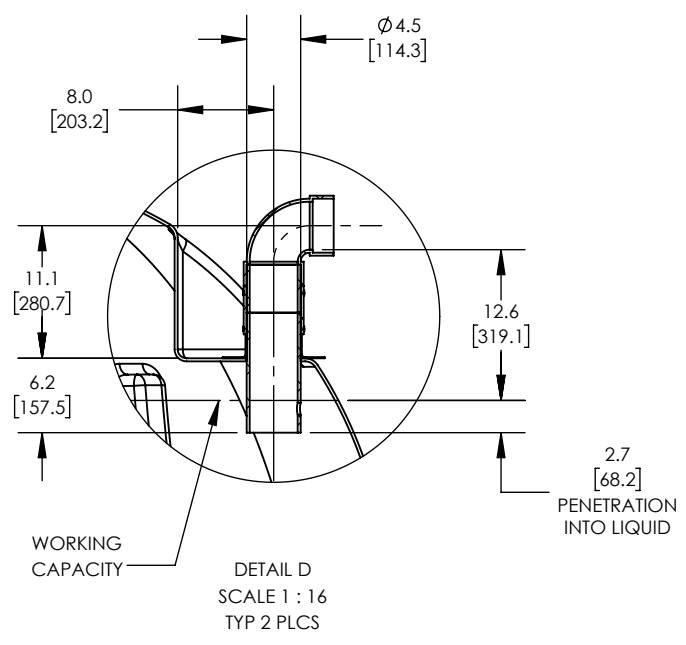
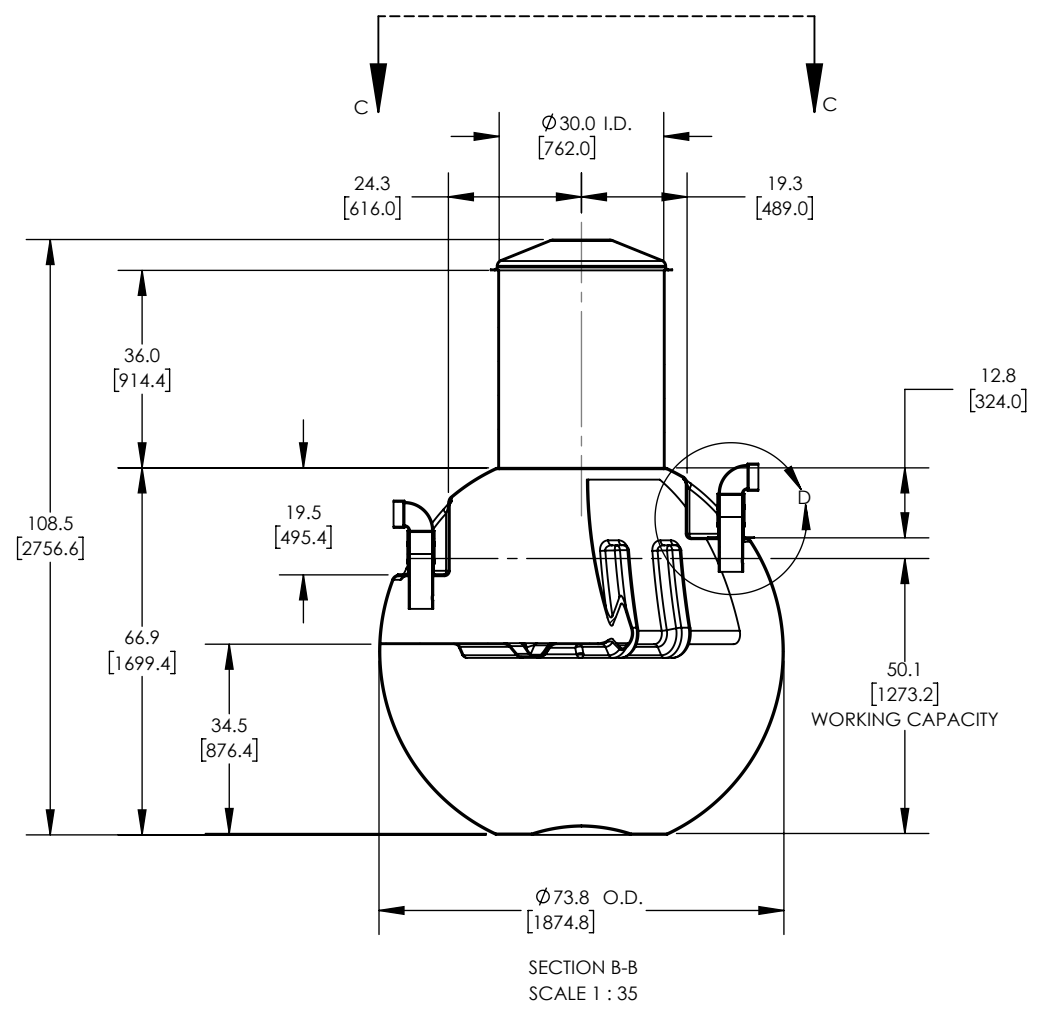

DIMENSIONS ARE IN INCHES
UNLESS OTHERWISE SPECIFIED

TOLERANCES:
.X ±0.12
.XX ±0.06
.XXX ±0.03
ANGULAR ±0.5°
UNLESS OTHERWISE SPECIFIED

MATERIAL: FRP

INITIAL RELEASE DATE:

DRAWN BY: AZ

CHECKED BY:

REV	DATE	DRN	CHK	DESCRIPTION	INITIAL RELEASE
					1035 MISSION STREET WINNIPEG, MB, CANADA R2J 0A4 (204) 233-0671 WWW.CARLSONCOMPOSITES.COM INFO@CARLSONCOMPOSITES.COM
THE INFORMATION CONTAINED IN THIS DRAWING IS THE SOLE PROPERTY OF CARLSON ENGINEERED COMPOSITES INC.. ANY REPRODUCTION IN PART OR AS A WHOLE WITHOUT THE WRITTEN PERMISSION OF CARLSON ENGINEERED COMPOSITES INC. IS PROHIBITED.					
CSA LABEL: CGR-3410T2.14 HGN-3410T2.14 CECGLB-750IG-T2.14				JOB NO:	
DWG. NO. CECGLB-750IG-T2.14				SIZE B	REV A
SCALE: NTS		ESTIMATED WEIGHT: 323 LBS/146 KG			SHEET 2 OF 4

4

3

2

1

B

B

A

A

4

3

2

1

EFFLUENT: AIR SPACE
VOLUME: 63 IMP. GAL
[287 LITRES]

SEPTIC: AIR SPACE
VOLUME: 58 IMP. GAL
[263 LITRES]

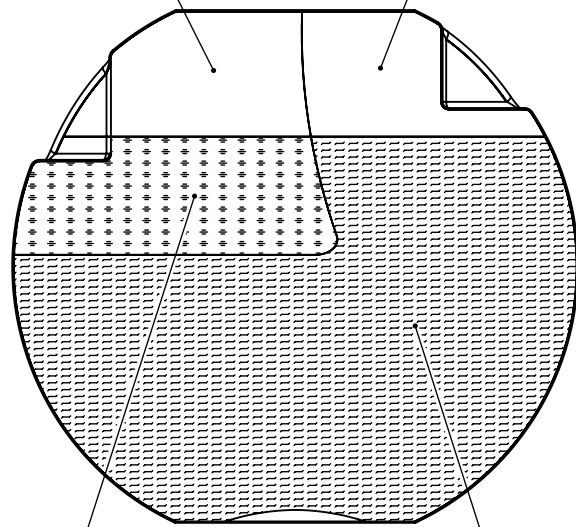

SECTION F-F
SCALE 1 : 25

EFFLUENT: WORKING CAPACITY
VOLUME: 117 IMP. GAL
[532 LITRES]

SEPTIC: WORKING CAPACITY
VOLUME: 488 IMP. GAL
[2219 LITRES]

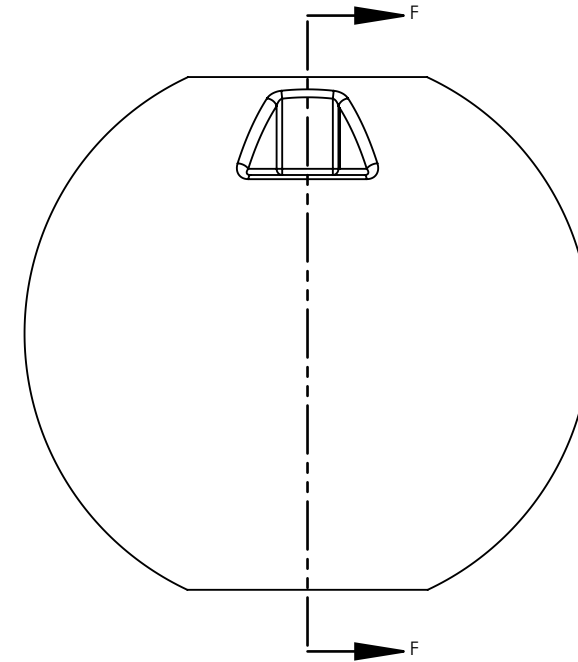

B

B

A

A

VOLUME TABLE

COMPARTMENT	WORKING CAPACITY		AIR SPACE		TOTAL	
	IMP. GAL	LITRES	IMP. GAL	LITRES	IMP. GAL	LITRES
SEPTIC	488	2219	58	263	546	2482
EFFLUENT	117	532	63	287	180	819
TOTAL TANK	605	2751	121	550	726	3301

DIMENSIONS ARE
IN INCHES
UNLESS OTHERWISE SPECIFIED

TOLERANCES:
.X ±0.12
.XX ±0.06
.XXX ±0.03
ANGULAR ±0.5°
UNLESS OTHERWISE SPECIFIED

MATERIAL:
FRP

INITIAL RELEASE DATE:

DRAWN BY: AZ

CHECKED BY:

A		AZ		INITIAL RELEASE
REV	DATE	DRN	CHK	DESCRIPTION

CARLSON ENGINEERED COMPOSITES
 1035 MISSION STREET
 WINNIPEG, MB, CANADA R2J 0A4
 (204) 233-0671
 WWW.CARLSONCOMPOSITES.COM
 INFO@CARLSONCOMPOSITES.COM

THE INFORMATION CONTAINED IN THIS DRAWING IS THE SOLE PROPERTY OF CARLSON ENGINEERED COMPOSITES INC.. ANY REPRODUCTION IN PART OR AS A WHOLE WITHOUT THE WRITTEN PERMISSION OF CARLSON ENGINEERED COMPOSITES INC. IS PROHIBITED.

CSA LABEL: CGR-3410T2.14
HGN-3410T2.14
CECGLB-750IG-T2.14

DWG. NO. CECGLB-750IG-T2.14

SCALE: NTS ESTIMATED WEIGHT: 323 LBS/146 KG

SHEET 3 OF 4

4

3

2

1